

SULIT



**BAHAGIAN PEPERIKSAAN DAN PENILAIAN
JABATAN PENDIDIKAN POLITEKNIK DAN KOLEJ KOMUNITI
KEMENTERIAN PENDIDIKAN MALAYSIA**

JABATAN KEJURUTERAAN MEKANIKAL

PEPERIKSAAN AKHIR

SESI JUN 2019

DJJ2022 : ELECTRICAL TECHNOLOGY

TARIKH : 02 NOVEMBER 2019

MASA : 2.30 PETANG – 4.30 PETANG (2 JAM)

Kertas ini mengandungi **SEMBILAN (9)** halaman bercetak.

Struktur (4 soalan)

Dokumen sokongan yang disertakan : Formula

JANGAN BUKA KERTAS SOALAN INI SEHINGGA DIARAHKAN

(CLO yang tertera hanya sebagai rujukan)

SULIT

INSTRUCTION:

This section consists of **FOUR (4)** structured questions. Answer **ALL** questions.

ARAHAN:

Bahagian ini mengandungi EMPAT (4) soalan struktur. Jawab SEMUA soalan.

QUESTION 1**SOALAN 1**CLO1
C1

(a) Define the following terms and state its formula;

Takrifkan istilah dibawah dan nyatakan formulanya;

i. Ohm's Law

Hukum Ohm

[3 marks]

[3 markah]

ii. Electrical Energy

Tenaga Elektrik

[3 marks]

[3 markah]

CLO1
C2

(b) Explain **FOUR (4)** factors that affect the value of resistance

Terangkan EMPAT (4) faktor yang mempengaruhi nilai rintangan

[10 marks]

[10 markah]

CLO1
C3

- (c) Referring to **Figure 1 (c)**, a 120V source is connected to the circuit. If $R_1 = 10\Omega$, $R_2 = 20\Omega$, $R_3 = 15\Omega$. Calculate :

*Merujuk kepada **Rajah 1 (c)**, punca bekalan 120V disambung ke litar. Jika $R_1 = 10\Omega$, $R_2 = 20\Omega$, $R_3 = 15\Omega$. Kirakan :*

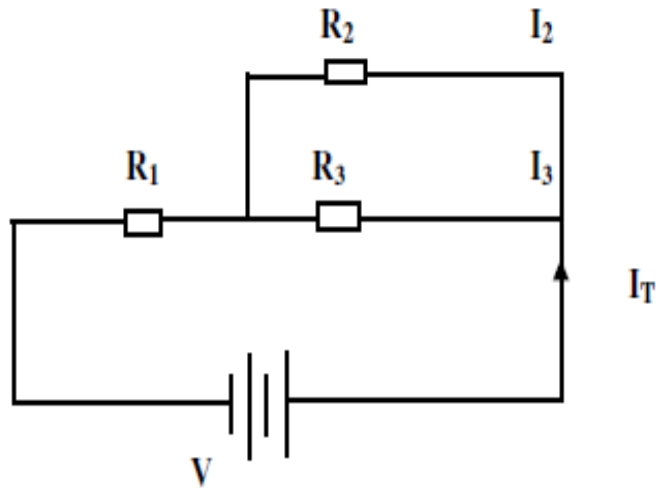

Figure 1 (c) / Rajah 1 (c)

- i. Total resistance, R_T
Jumlah rintangan, R_T

[3 marks]
[3 markah]

- ii. Total current, I_T
Jumlah arus, I_T

[3 marks]
[3 markah]

- iii. Current I_2 and I_3
Arus I_2 dan I_3

[3 marks]
[3 markah]

QUESTION 2

SOALAN 2

- CLO1
C1 (a) Describe **TWO (2)** types of inductors and it's functions
Terangkan DUA (2) jenis peraruh dan fungsinya
- [5 marks]
[5 markah]
- CLO1
C2 (b) Express the value of total capacitance with the aid of diagram of three capacitors which each of it has $120\mu\text{F}$ of capacitance connected in:
Nyatakan jumlah kemuatan bagi tiga pemuat dengan bantuan gambarajah dengan nilai kemuatan bagi setiap pemuat adalah $120\mu\text{F}$ apabila ia disambung secara:
- i. Series
Siri
- [4 marks]
[4 markah]
- ii. Parallel
Selari
- [4 marks]
[4 markah]
- CLO1
C3 (c) A RL series circuit has 10Ω resistor, 0.2H inductor and is supplied with 250V , 50Hz AC.
Sebuah litar siri RL mempunyai 10Ω perintang, 0.2H peraruh dan voltan bekalan 250V , 50Hz AC.
- i. Sketch the diagram of the series circuit
Lakarkan gambarajah litar sesiri tersebut
- [2 marks]
[2 markah]
- Calculate :
Kirakan :
- ii. Impedance, Z
Galangan, Z
- [4 marks]
[4 markah]

iii. Current, I

Arus, I

[3 marks]
[3 markah]

iv. Phase angle, Θ

Sudut fasa, Θ

[3 marks]
[3 markah]

QUESTION 3

SOALAN 3

CLO1
C1

(a) Identify factors that affect electromagnetic strength

Kenalpasti faktor-faktor yang mempengaruhi kekuatan elektomagnet

[5marks]
[5 markah]

CLO1
C2

(b) Interpret and express the unit for each of the terms below :

Huraikan dan nyatakan unit bagi setiap terma dibawah :

i. Magnetomotive Force, Fm

Daya medan magnet, Fm

[2 marks]
[2 markah]

ii. Magnetic Field Strength, H

Kekuatan medan magnet, H

[2 marks]
[2 markah]

iii. Magnetic Flux Density, B

Ketumpatan fluks magnet, B

[2 marks]
[2 markah]

CLO1
C3

- (c) A ring iron core has a mean circumference of 250 mm and a cross sectional area of 110mm^2 . It is wound with 2000 turns. Through measurement, the value of fluxes in the iron is 0.2 mWb when 65mA current flows through the winding. Calculate:

Satu teras besi berbentuk gelang yang mempunyai purata ukurlilit sebanyak 250mm dan luas keratan rentas ialah 110mm^2 . Teras itu dililit dengan 2000 lilitan pengalir. Melalui pengukuran, didapati 0.2mWb fluks wujud apabila 65mA melalui lilitan tersebut. Kirakan:

Given the permeability of free space, $\mu_0 = 4\pi \times 10^{-7} \text{ H/m}$

Diberi nilai ketelapan ruang bebas, $\mu_0 = 4\pi \times 10^{-7} \text{ H/m}$

- i. Flux density, B

Ketumpatan fluks, B

[3 marks]

[3 markah]

- ii. Magnetic field strength, H

Kekuatan medan magnet, H

[3 marks]

[3 markah]

- iii. Absolute permeability, μ_a

Ketelapan mutlak, μ_a

[3 marks]

[3 markah]

- iv. Relative permeability, μ_r

Ketelapan bandingan, μ_r

[2 marks]

[2 markah]

- v. Iron core reluctance, S

Engganan teras besi, S

[3 marks]

[3 markah]

QUESTION 4**SOALAN 4**

- CLO1
C1
- (a) Describe the operational principle of a transformer with the aid of diagram
Jelaskan prinsip kerja bagi sebuah pengubah dengan bantuan gambarajah
- [5 marks]
[5 markah]
- CLO1
C3
- (b) An ideal 25 kVA transformer has 500 turns on the primary winding and 40 turns on the secondary winding. The primary is connected to 3000 V, 50 Hz supply. Calculate :
Sebuah pengubah ideal 25kVA mempunyai 500 lilitan pada bahagian primer dan 40 lilitan pada bahagian sekunder. Bahagian primer disambung kepada 3000V, 50Hz bekalan. Kirakan :
- i. Primary and secondary currents on full-load
Arus primer dan sekunder ketika beban penuh
- [6 marks]
[6 markah]
- ii. Secondary voltage
Voltan sekunder
- [3 marks]
[3 markah]
- iii. Maximum core flux
Fluks maksimum teras
- [3 marks]
[3 markah]

CLO1
C2

(c) Three phase induction motor, 6 poles, 50 Hz is rotating at a speed of 3% slip.

Express the value of :

Sebuah motor aruhan 3 fasa, 6 kutub, 50 Hz berputar dengan kelajuan 3% gelincir. Nyatakan nilai untuk :

i. Synchronous speed, N_s

Kelajuan segerak, N_s

[5 marks]

[5 markah]

ii. Rotor speed, N_r

Kelajuan rotor, N_r

[3 marks]

[3 markah]

SOALAN TAMAT

DJJ 2022 – ELECTRICAL TECHNOLOGY

FORMULA

INTRODUCTION TO ELECTRICAL CIRCUITS $R = \frac{\rho \ell}{A}$ $V = IR$ $P = IV$ $E = Pt$ $C = \frac{Q}{V}$ KIRCHOFF'S LAW $V_j = V_1 + V_2 + V_3$ $\Sigma I_{IN} = \Sigma I_{OUT}$ $I_1 = I_2 + I_3$ SERIES $V_T = V_1 + V_2 + \dots + V_n$ $I_T = I_1 = I_2 = \dots = I_n$ $R_T = R_1 + R_2 + \dots + R_n$ $L_T = L_1 + L_2 + \dots + L_n$ $\frac{1}{C_T} = \frac{1}{C_1} + \frac{1}{C_2} + \dots + \frac{1}{C_n}$ $V_x = \frac{R_x}{R_T} V_T$ PARALLEL $V_T = V_1 = V_2 = \dots = V_n$ $I_T = I_1 + I_2 + \dots + I_n$ $\frac{1}{R_T} = \frac{1}{R_1} + \frac{1}{R_2} + \dots + \frac{1}{R_n}$ $\frac{1}{L_T} = \frac{1}{L_1} + \frac{1}{L_2} + \dots + \frac{1}{L_n}$ $C_T = C_1 + C_2 + \dots + C_n$ $I_x = \frac{R_T}{R_x} I_T$	ALTERNATING CURRENT CIRCUIT RL CIRCUIT $I = \frac{V}{Z}$ $V_L = IX_L$ $Z = \sqrt{R^2 + X_L^2}$ $\theta = \tan^{-1} \left[\frac{X_L}{R} \right]$ $\text{Cos } \theta = \frac{R}{Z}$ RC CIRCUIT $I = \frac{V}{Z}$ $V_C = IX_C$ $Z = \sqrt{R^2 + X_C^2}$ $\theta = -\tan^{-1} \left[\frac{X_C}{R} \right]$ $\text{Cos } \theta = \frac{R}{Z}$ RLC CIRCUIT $I = \frac{V}{Z}$ $V_L = IX_L$ $V_R = IR$ $V_C = IX_C$ $Z = \sqrt{R^2 + (X_L - X_C)^2}$ $\theta = \tan^{-1} \left[\frac{X_L - X_C}{R} \right]$ $\text{Cos } \theta = \frac{R}{Z}$	AC MACHINES $N_s = \frac{120f}{P}$ $\%S = \frac{N_s - N_r}{N_s} \times 100$ $N_r = N_s(1 - S)$ $f_r = Sf$ $E = 2.22K_d K_p f \phi Z$ TRANSFORMER $\frac{V_p}{V_s} = \frac{N_p}{N_s} = \frac{I_s}{I_p}$ $E_1 = 4.44fN_1\Phi_m$ $E_2 = 4.44fN_2\Phi_m$ Complex Power, S (VA) = VI Actual Power, P (W) = VI cos θ Reactive Power, Q (VAR) = VI sin θ I = $\frac{\text{Power}}{\text{Voltage}}$ Power losses = Core losses + Ip ² Rp + Is ² Rs Output power = Power x power factor Input power = output power + power losses Efficiency, %η = $\frac{\text{output power}}{\text{Input power}} \times 100$ ELECTROMAGNET $H = \frac{Fm}{l} = \frac{NI}{l}$ $B = \frac{\Phi}{A}$ $B = \mu H$ $\mu = \mu_o \mu_r$ $S = \frac{Fm}{\Phi} @ \frac{l}{\mu A}$
---	--	---