

**SULIT**



**BAHAGIAN PEPERIKSAAN DAN PENILAIAN  
JABATAN PENDIDIKAN POLITEKNIK DAN KOLEJ KOMUNITI  
KEMENTERIAN PENGAJIAN TINGGI**

**JABATAN KEJURUTERAAN AWAM**

**PENILAIAN ALTERNATIF**

**SESI 1 : 2021/2022**

**DCC40163 : THEORY OF STUCTURES**

---

**NAMA PENYELARAS KURSUS : YUSNITA BINTI YUSOF**

**KAEDAH PENILAIAN : PEPERIKSAAN DALAM TALIAN**

**JENIS PENILAIAN : BAHAGIAN A:  
SOALAN STRUKTUR (2 SOALAN)**

**BAHAGIAN B:  
SOALAN ESEI (1 SOALAN)**

**TARIKH PENILAIAN : 3 FEBRUARI 2022**

**TEMPOH PENILAIAN : 1 JAM 30 MINIT**

---

**LARANGAN TERHADAP PLAGIARISM (AKTA 174)**

**PELAJAR TIDAK BOLEH MEMPLAGIAT APA-APA IDEA, PENULISAN, DATA  
ATAU CIPTAAN ORANG LAIN. PLAGIAT ADALAH SALAH SATU  
PENYELEWENGAN AKADEMIK. SEKIRANYA PELAJAR DIBUKTIKAN  
MELAKUKAN PLAGIARISM, PENILAIAN BAGI KURSUS BERKENAAN AKAN  
DIMANSUHKAN DAN DIBERI GRED F DENGAN NILAI MATA 0.**

**(RUJUK BUKU ARAHAN-ARAHAN PEPERIKSAAN DAN KAEDAH PENILAIAN (Diploma) EDISI 6, JUN 2019,  
KLAUSA 17.3)**

**SECTION A: 50 MARKS****BAHAGIAN A : 50 MARKAH****INSTRUCTION:**

This paper consists of **TWO (2)** structured questions. Answer **ALL** questions.

**ARAHAN:**

Kertas ini mengandungi **DUA (2)** soalan berstruktur. Jawab **SEMUA** soalan.

**QUESTION 1****SOALAN 1**

- (a) **Figure A1(a)** show a continuous beam is subjected to a point load and distributed load. Calculate internal moment at support A, B and C by using the Slope Deflection Method.

*Rajah A1(a)* menunjukkan sebuah rasuk selanjur dikenakan tindakan daya tumpu dan daya teragih seragam. Kirakan momen dalaman pada penyokong A, B and C dengan menggunakan Kaedah Cerun Pesongan.

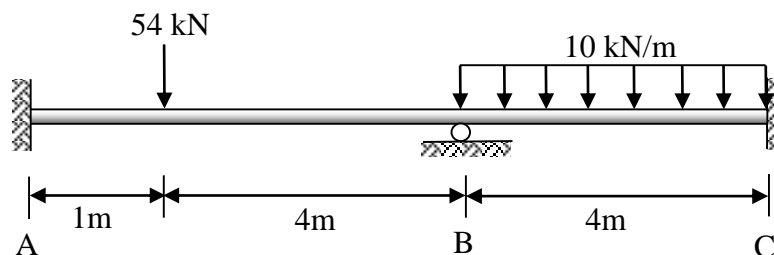

**Figure A1(a) / Rajah A1(a)**

CLO1  
C2

- i. Express the moment equation for each span of the beam.  
*Ungkapkan persamaan moment bagi setiap rentang rasuk.*

[6 marks]

[6 markah]

CLO1  
C3

- ii. Calculate the internal moment at support A, B and C.  
*Kirakan momen dalaman pada penyokong A, B dan C.*

[6 marks]

[6 markah]

- (b) A non-sway portal frame is loaded as shown in **Figure A1(b)**. The value of Internal Moment are given in **Table A1(b)**. Based on **Figure A1(b)** and **Table A1(b)**:

*Sebuah kerangka portal tanpa huyung dikenakan beban seperti ditunjukkan dalam **Rajah A1(b)**. Nilai Moment Dalaman diberikan dalam **Jadual A1(b)**. Berdasarkan **Rajah A1(b)** dan **Jadual A1(b)**:*

**Table A1(b) / Jadual A1(b)**

Joint <i>Sambungan</i>	Internal Moment <i>Moment Dalaman</i>
A	$M_{AB} = -40.167 \text{ kNm}$
B	$M_{BA} = 15.667 \text{ kNm}$
	$M_{BC} = -15.667 \text{ kNm}$
C	$M_{CB} = 3.416 \text{ kNm}$

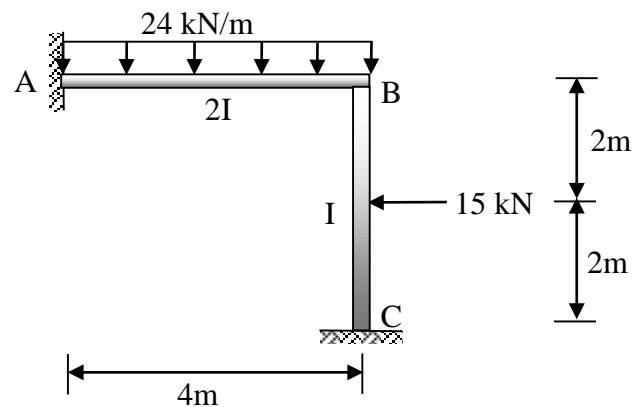

**Figure A1(b) / Rajah A1(b)**

- CLO1  
C2
- i. Identify the reaction at each support for the portal frame.  
*Kenal pasti tindak balas pada setiap penyokong bagi kerangka portal.*
- [6 marks]  
[6 markah]
- CLO1  
C3
- ii. Sketch the Shear Force Diagram (SFD) and Bending Moment Diagram (BMD).  
*Lakarkan Gambarajah Daya Ricih (GDR) dan Gambarajah Momen Lentur (GML).*
- [7 marks]  
[7 markah]

## QUESTION 2

## SOALAN 2

- (a) **Figure A2(a)** show a statically determinate truss is subjected to external loads. The cross sectional area,  $A = 450\text{mm}^2$  and modulus of elasticity,  $E = 210\text{kN/mm}^2$ . Given reaction at support A are  $R_A = 22.5\text{kN}$  and  $H_A = -40\text{kN}$ . Whereas, reaction at support C is  $R_C = 62.5\text{kN}$ .

**Rajah A2(a)** menunjukkan sebuah kekuda boleh tentu statik dikenakan beban luaran. Luas keratan rentas,  $A = 450\text{mm}^2$  dan modulus keanjalan,  $E = 210\text{kN/mm}^2$ . Diberi tindak balas pada penyokong A ialah  $R_A = 22.5\text{kN}$  dan  $H_A = -40\text{kN}$ . Manakala, tindak balas pada penyokong C ialah  $R_C = 62.5\text{kN}$ .

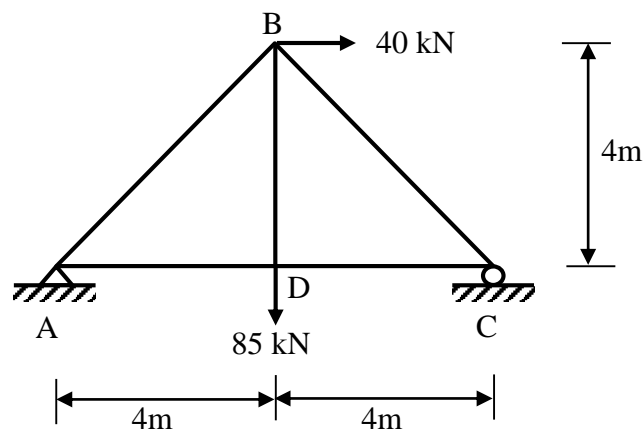

**Figure A2(a) / Rajah A2(a)**

CLO2  
C3

- i. Calculate the internal forces in each member of the truss due to the external load.

*Kirakan daya dalaman setiap anggota kekuda yang disebabkan oleh daya luaran.*

[6 marks]

[6 markah]

CLO2  
C4

- ii. Based on **Figure A2(a)**, analyze the vertical displacement of Joint D if the internal forces in each member of the truss due to the vertical unit load at joint D are given in **Table A2(a)**.

*Berdasarkan **Rajah A2(a)**, analisis anjakan pugak sendi D jika daya dalaman dalam setiap anggota kekuda disebabkan oleh beban unit menegak pada sambungan D diberikan dalam **Jadual A2(a)**.*

**Table A2(a) / *Jadual A2(a)***

<b>Member</b>	<b><math>\mu_i</math></b>
<b>AB</b>	- 0.707
<b>AD</b>	- 0.5
<b>BC</b>	- 0.707
<b>BD</b>	1
<b>CD</b>	- 0.5

[6 marks]

[6 markah]

- (b) A statically indeterminate truss is subjected to an external load as shown in **Figure A2(b)**. The cross-sectional area and Modulus of Young are constant for each member. The internal forces in all members of the truss which was caused by the external force are given in **Table A2(b)**.

*Sebuah kekuda tak boleh tentu statik dikenakan beban luaran seperti ditunjukkan dalam **Rajah A2(b)**. Luas keratan rentas dan Modulus Young adalah malar bagi setiap anggota. Daya dalaman bagi semua anggota kekuda disebabkan oleh daya luaran diberikan dalam **Jadual A2(b)**.*

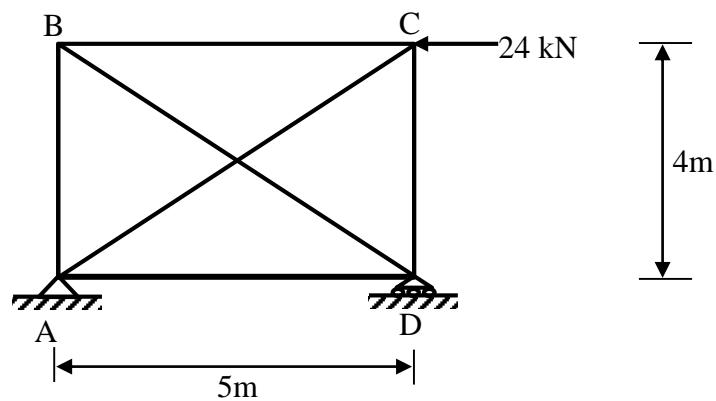

**Figure A2(b) / Rajah A2(b)**

**Table A2(b) / Jadual A2(b)**

Member	$P_i$ (kN)
AB	- 19.2
AC	0
AD	- 24
BC	- 24
BD	30.735
CD	0

CLO2  
C3

- i. Calculate the internal forces,  $\mu_i$ , in all members of the truss due to internal virtual unit force at AC member.

*Hitungkan daya dalaman,  $\mu_i$ , bagi semua anggota kekuda yang disebabkan oleh beban unit pada anggota AC.*

[7 marks]

[7 markah]

CLO2  
C4

- ii. Then, analyze magnitude redundant, R.

*Kemudian, analisis magnitud lelebih, R.*

[6 marks]

[6 markah]

**SECTION B: 50 MARKS****BAHAGIAN B: 50 MARKAH****INSTRUCTION:**

This section consists of **ONE (1)** structured questions. Answer **ALL** questions.

**ARAHAN:**

Bahagian ini mengandungi **SATU (1)** soalan berstruktur. Jawab **SEMUA** soalan.

**QUESTION 1****SOALAN 1**

CLO3  
C4

- (a) A simply supported beam is subjected to a series of moving loads as shown in **Figure B1(a)**. By using Influence Line Diagram, analyze the maximum shear force and bending moment at point B due to a series of loads moving from A to C.

*Sebuah rasuk ditupang mudah dikenakan satu siri daya bergerak seperti ditunjukkan dalam **Rajah B1(a)**. Dengan menggunakan Gambarajah Garis Imbas, analisis daya ricih dan momen lentur maksimum di titik B disebabkan oleh pergerakan satu siri beban bergerak dari A ke C.*

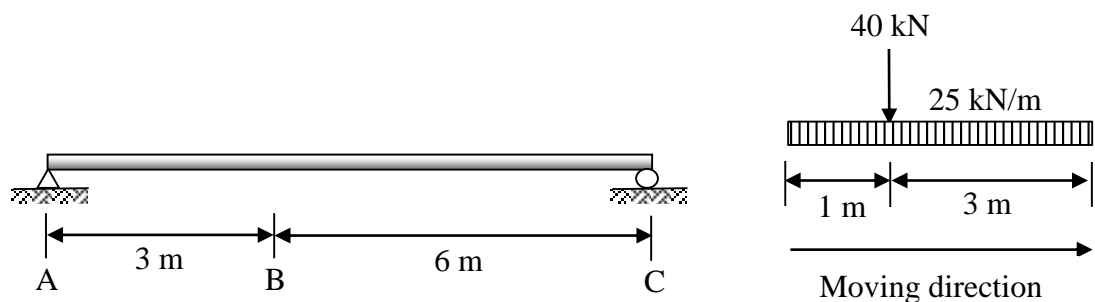

**Figure B1(a) / Rajah B1(a)**

[10 marks]

[10 markah]



CLO3  
C5

- (b) **Figure B1(b)** shows a simply supported beam is subjected to a series of moving loads 40 kN, 70 kN, 70 kN and 60 kN respectively. Evaluate the Absolute Maximum Moment due to a series of loads moving from left to right by using Influence Line Diagram.

*Rajah B1(b)* menunjukkan rasuk ditupang mudah dikenakan satu siri daya bergerak masing-masing 40 kN, 70 kN, 70 kN dan 60 kN. Nilai Momen Maksimum Mutlak yang disebabkan oleh pergerakan satu siri beban dalam satu arah dari kiri ke kanan dengan menggunakan Gambarajah Garis Imbas.

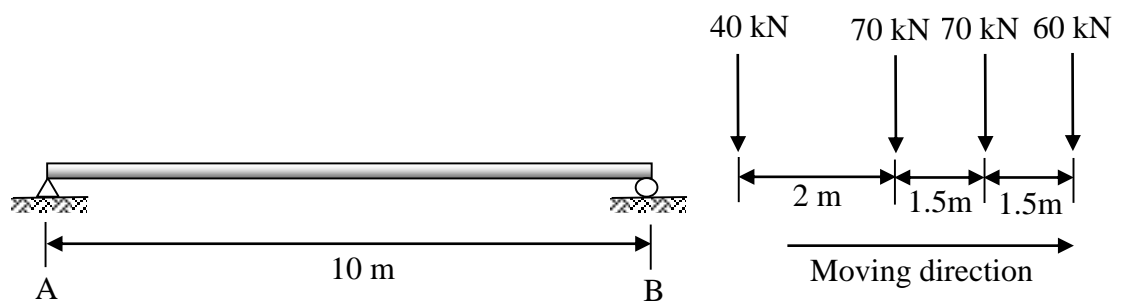

**Figure B1(b) / Rajah B1(b)**

[15 marks]

[15 markah]

**SOALAN TAMAT**

## DCC40163 THEORY OF STRUCTURES FORMULAE

<b>1. Slope Deflection Method</b>	
$M_{AB} = \frac{2EI}{L} (2\theta_A + \theta_B) + FEM_{AB}$ $M_{BA} = \frac{2EI}{L} (2\theta_B + \theta_A) + FEM_{BA}$	
<b>2. Moment Distribution Method</b>	
i. Stiffness Factor	For fixed or continuous $K = \frac{4EI}{L}$
	For pinned or roller $K = \frac{3EI}{L}$
ii. Distribution Factor	$DF = \frac{K}{\sum K}$
<b>3. Statically Indeterminate Truss</b>	
i. Redundant Force	$R = \frac{\sum P\mu L/AE}{\mu^2 L/AE}$
ii. Internal Force	$F = P + \mu R$
<b>4. Displacement</b>	
i. External Load	$\Delta = \frac{\sum P\mu L}{AE}$
<b>5. Influence Lines</b>	
$R_A = 1 - \frac{x}{L}$ $V_C = -\frac{x}{L}$ $M_C = \frac{bx}{L}$	$R_B = \frac{x}{L}$ $V_C = 1 - \frac{x}{L}$ $M_C = a \left(1 - \frac{x}{L}\right)$

Table 1: Fixed End Moment (FEM)

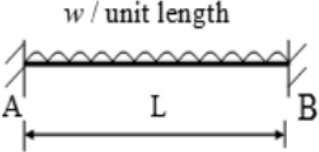
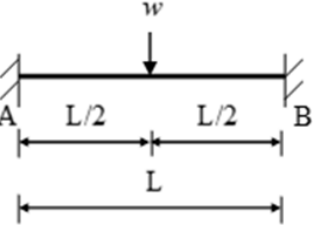
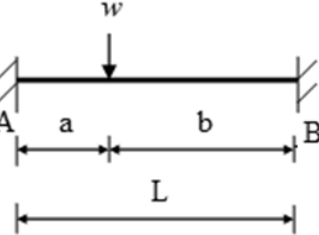
$FEM_{AB} = -\frac{wL^2}{12}$	 <p style="text-align: center;">w / unit length</p>	$FEM_{BA} = +\frac{wL^2}{12}$
$FEM_{AB} = -\frac{wL}{8}$		$FEM_{BA} = +\frac{wL}{8}$
$FEM_{AB} = -\frac{wab^2}{L^2}$		$FEM_{BA} = +\frac{wa^2b}{L^2}$