

**SULIT**



**KEMENTERIAN PENDIDIKAN TINGGI  
JABATAN PENDIDIKAN POLITEKNIK DAN KOLEJ KOMUNITI**

**BAHAGIAN PEPERIKSAAN DAN PENILAIAN  
JABATAN PENDIDIKAN POLITEKNIK DAN KOLEJ KOMUNITI  
KEMENTERIAN PENDIDIKAN TINGGI**

**JABATAN KEJURUTERAAN AWAM**

**PEPERIKSAAN AKHIR**

**SESI II : 2022/2023**

**DCC20073 : CONTRACT & ESTIMATING**

**TARIKH : 21 JUN 2023**

**MASA : 8.30 PG – 10.30 PG (2 JAM)**

---

Kertas ini mengandungi **SEBELAS (11)** halaman bercetak.

Bahagian A: Subjektif (2 soalan)

Bahagian B: Subjektif (4 soalan)

Dokumen sokongan yang disertakan : Borang Ukur Kuantiti

---

**JANGAN BUKA KERTAS SOALAN INI SEHINGGA DIARAHKAN**

(CLO yang tertera hanya sebagai rujukan)

**SULIT**

**SECTION A : 50 MARKS****BAHAGIAN A : 50 MARKAH****INSTRUCTION:**

This section consists of **TWO (2)** subjective questions. Answers **ALL** questions.

**ARAHAN :**

*Bahagian ini mengandungi DUA (2) soalan subjektif. Jawab SEMUA soalan.*

**QUESTION 1****SOALAN 1**

- CLO1 (a) Identify **FIVE (5)** stages involved with construction industry from early stage until last stage referring to Figure A1.

*Kenal pasti LIMA (5) peringkat yang terlibat dengan industri pembinaan daripada peringkat awal sehingga peringkat akhir merujuk kepada Rajah A1.*

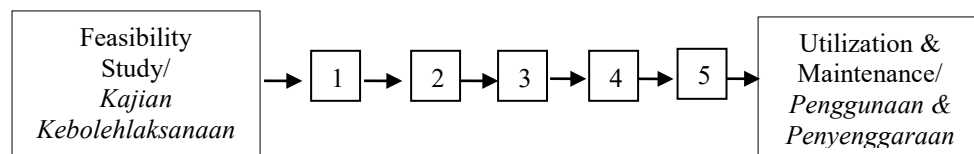

Figure A1 / Rajah A1

[5 marks]

[5 markah]

- CLO1 (b) Explain **FOUR (4)** terms of contract for main/prime contractor, domestic sub-contractor, nominated sub-contractor and nominated supplier.

*Terangkan EMPAT (4) terma berikut berdasarkan kontrak untuk kontraktor utama / kontraktor prima, subkontraktor domestik, subkontraktor dinamakan dan pembekal dinamakan.*

[10 marks]

[10 markah]

- CLO1 (c) TVET education sector had urgent need to develop for a specific project with a new specialized of field. Main Contractor is choosen as design consultants to carry out responsibilities in the design and construction. In this situation Turnkey contract is selected. Explain **FIVE (5)** characteristics for these contract.

*Sektor Pendidikan TVET berhasrat membangunkan dengan kadar segera satu projek spesifik dengan bidang kepakaran bidang baru. Kontraktor utama dipilih bertindak sebagai perunding untuk menggalas tanggungjawab bagi merekabentuk dan melaksanakan pembinaan. Di dalam situasi ini kontrak jenis Turnkey telah dipilih. Terangkan **LIMA (5)** ciri-ciri kontrak jenis tersebut.*

[10 marks]

[10 markah]

## QUESTION 2

### SOALAN 2

- CLO1 (a) Explain briefly quotation and tender.

*Terangkan dengan ringkas sebutharga dan tender.*

[5 marks]

[5 markah]

- CLO1 (b) Open tender is a type of tender used in procurement in the goverment and private sector. Explain **TWO (2)** characteristics and **THREE (3)** advantages of open tender.

*Tender terbuka adalah salah satu jenis tender yang digunakan di dalam perolehan di sektor kerajaan dan swasta. Jelaskan **DUA (2)** ciri-ciri dan **TIGA (3)** kebaikan tender terbuka.*

[10 marks]

[10 markah]

- CLO1 (c) Syarikat ABC and Syarikat DEF bid a tender for Construction of Guard House at PSMZA. Syarikat ABC had chosen as a contractor for that project. Explain **FIVE (5)** factors of tender rejection for Syarikat DEF.

*Syarikat ABC dan Syarikat DEF membida tender untuk Pembinaan Pondok Pengawal di PSMZA. Syarikat ABC telah dipilih sebagai kontraktor untuk melaksanakan projek tersebut. Terangkan **LIMA (5)** faktor penolakan tender oleh Syarikat DEF.*

[10 marks]

[10 markah]

**SECTION B : 50 MARKS**

**BAHAGIAN B : 50 MARKAH**

**INSTRUCTION:**

This section consists of **FOUR (4)** subjective questions. Answer **TWO (2)** questions only.

**ARAHAN:**

*Bahagian ini mengandungi **EMPAT (4)** soalan subjektif. Jawab **DUA (2)** soalan sahaja.*

**QUESTION 1**

**SOALAN 1**

- CLO2 (a) Unit Valuation method is one of preliminary estimating methods. Identify **TWO (2)** advantages of Unit Valuation method that made is relevant to use.

*Kaedah penilaian unit merupakan antara kaedah untuk menganggar taksiran awal. Kenal pasti **DUA (2)** kelebihan kaedah penilaian unit yang membuatkan ianya masih relevan untuk digunakan.*

[5 marks]

[5 markah]

- CLO2 (b) Based on Table B1(b), calculate the estimated construction cost for TVET center, which can accommodate 3500 students.

*Berdasarkan daripada jadual B1(b), kirakan anggaran kos pembinaan bagi pusat TVET yang dapat menempatkan 3500 orang murid.*

Table B1(b) / *Jadual B1(b)*

Type <i>Jenis</i>	Construction Cost <i>Kos Pembinaan (RM )</i>	No. of students <i>Bilangan pelajar</i>
Center Training A	5,500,000.00	2000
Center Training B	2,800,000.00	1500

[10 marks]

[10 markah]

- CLO2 (c) Based on Table B1(c), the given price rate for 1 meter cube building is RM 560. Estimate the price of the school building if construction cost increases at the rate of 15% using cubic method.

*Berdasarkan jadual B1(c), diberi kadar harga 1 meterpadu bangunan adalah RM 560. Anggarkan harga bangunan jika kenaikan kos sebanyak 15% menggunakan kaedah isipadu.*

Table B1(c) / *Jadual B1(c)*

Building <i>Bangunan</i>	Length <i>panjang</i> mm	Width <i>lebar</i> mm	Height <i>tinggi</i> mm
PolyCC	6200	3500	4500

Assume all roofs are flat roof /*Anggap semua bumbung rata*

[10 marks]

[10 markah]

## QUESTION 2

## SOALAN 2

- CLO2 (a) Explain **TWO (2)** purposes of scheduled of price rate in tender document.  
*Terangkan DUA (2) tujuan jadual kadar harga di dalam dokumen tender.*
- [5 marks]  
[5 markah]
- CLO2 (b) Based on the information in Table B2(b), calculate the build up cost for mixing concrete work manually.  
*Berdasarkan maklumat dalam Jadual B2(b), kirakan kadar bina harga bagi kerja-kerja membancuh konkrit secara manual.*

Table B2(b) : Mixing Concrete Data

Jadual B2(b) : Data Bancuhan Konkrit

Important information: <i>Maklumat penting:</i>	
Concrete grade 25 (1 : 2 : 4) / <i>Konkrit gred 25 (1 : 2 : 4)</i>	
1m <sup>3</sup> cement (50kg) / <i>1m<sup>3</sup> simen (50kg)</i>	= 28.7 bags / <i>28.7 beg</i>
Price of a bag of cement / <i>Harga bagi 1 beg simen</i>	= RM20.00
Price of 1m <sup>3</sup> sand / <i>Harga bagi 1m<sup>3</sup> pasir</i>	= RM26.00
Price of 1m <sup>3</sup> coarse aggregate / <i>Harga bagi 1m<sup>3</sup> batu baur kasar</i>	= RM40.00
Increase in volume due to shrinkage, wastage and compaction of concrete / <i>Penambahan isipadu akibat pengecutan, pembaziran dan pepadatan konkrit</i>	= 50%
Labour cost for 1 worker per day (8 hour) / <i>Kos buruh bagi 1 orang pekerja sehari (8 jam)</i>	= RM45.00
Labour constant cost for mixing concrete using hand / <i>Angkatap buruh untuk menggaul konkrit menggunakan tangan</i>	= 2.5 hour/m <sup>3</sup> = 2.5 jam/m <sup>3</sup>
Labour constant cost for transporting and casting concrete into formwork per day / <i>Angkatap buruh untuk mengangkut dan menuang konkrit ke dalam acuan sehari</i>	= 8.00 hour/m <sup>3</sup> = 8.00 jam/m <sup>3</sup>
Profit & overhead / <i>Keuntungan &amp; overhed</i>	= 20%

[10 marks]

[10 markah]

CLO2

- (c) Table B2(c) shows the information for construction of pad footing F1 & F2. Calculate the price rate of concrete works mixed manually for F1 and F2 pad foundation.

*Jadual B2(c) menunjukkan maklumat untuk pembinaan asas papak F1 dan F2. Kirakan kadar harga kerja konkrit secara manual bagi asas papak F1 dan F2.*

Table B2(c) / *Jadual B2(c)*

<u>Materials /Bahan</u>			
Cement / <i>Simen</i> : RM 23.50 / bag			
Sand / <i>Pasir</i> : RM 50.00 / m <sup>3</sup>			
Aggregate / <i>Batubaur</i> : RM 60.00 / m <sup>3</sup>			
<u>Labour Constant /Angkatap buruh</u>			
Remove and replace concrete/ <i>penuangan konkrit</i> : 0.75 hour/m <sup>3</sup>			
Compact concrete / <i>Pemadatan konkrit</i> : 0.50 hour/m <sup>3</sup>			
<u>Others/ Lain-lain</u>			
Operator wage / <i>Upah pekerja</i> : RM 75.00/ hour			
Worker / <i>pekerja</i> : 2 persons/orang			
Profit & overhead/ <i>Keuntungan dan kos pengurusan</i> : 25%			
Concrete ratio/ <i>nisbah konkrit</i> : 1 : 3 : 6 – 19mm aggregate			
(Assume 1m <sup>3</sup> concrete/ <i>Anggaran 1m<sup>3</sup>konkrit</i> = 28.7 bag cement/ <i>kampit simen</i> )			
FOOTING / <i>ASAS</i>	SIZE / <i>SAIZ (m)</i>	DEPTH/ <i>KEDALAMAN</i> ( <i>m</i> )	NOS/ <i>BILANGAN</i>
F1	1.20 x 1.20 x 0.70	1.60	5
F2	1.00 x 1.00 x 0.35	1.50	3

[10 marks]

[10 markah]

**QUESTION 3****SOALAN 3**

CLO2 (a) Identify **FIVE (5)** functions of Bills of Quantities.

*Kenal pasti LIMA (5) fungsi senarai kuantiti.*

[5 marks]

[5 markah]

CLO2 (b) Based on the Figure B3(b), calculate the volume of earthwork by using Triangle Method.

*Berdasarkan Rajah B3(b), kirakan isipadu kerja tanah menggunakan Kaedah Segitiga.*

Data given / Diberi data :

Interval / Jarak sela = 10 meter

Formation level / Aras pembentukan = 96 meter

Top soil / Tanah permukaan = 150 mm

A1	97.50	B1	96.65	C1	94.60
A2	99.25	B2	97.90	C2	98.50
A3	99.60	B3	97.70	C3	90.12

Figure B3(b) / Rajah B3(b)

[10 marks]

[10 markah]



- CLO2 (c) Referring to Figure B3(c) and information given, estimate the quantity for supply of initial piles and supply of extension piles.

*Merujuk kepada Rajah B3(c) dan maklumat yang diberikan, anggarkan kuantiti untuk kerja membekal cerucuk permulaan dan membekal cerucuk sambungan.*

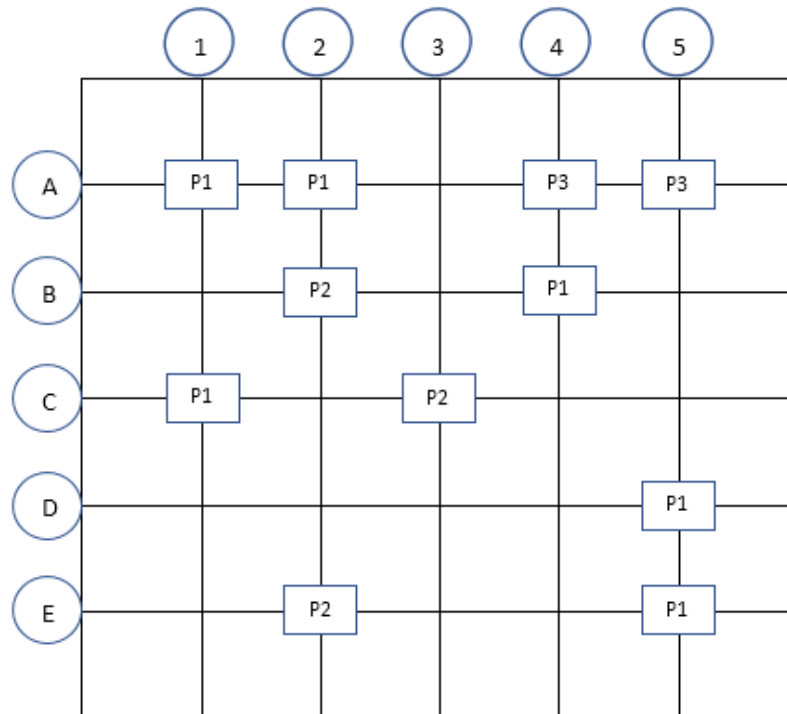

Figure B3(c) : Piling Layout Plan

*Rajah B3(c) : Pelan Susun Atur Cerucuk*

Data / Maklumat:

1. All piles are 200mm x 200mm precast concrete pile  
*Semua cerucuk adalah dari jenis 200mm x 200mm cerucuk pra tuang*
2. Length starter pile / *panjang cerucuk permulaan*: 12m
3. Length extension pile / *panjang cerucuk sambungan*: 9m
4. Provision depth of driven piles 26m  
*Kedalaman penanaman sementara cerucuk adalah 26m*
5. Legend/ *Simbol*:
  - P1 – Pile cap with 1 point/ *Tetopi cerucuk dengan 1 point*
  - P2 - Pile cap with 2 point/ *Tetopi cerucuk dengan 2 point*
  - P3 - Pile cap with 3 point/ *Tetopi cerucuk dengan 3 point*

[10 marks]

[10 markah]

## QUESTION 4

## SOALAN 4

CLO2

- (a) Identify the taking off list for column and its units.  
*Kenal pasti senarai ukur kuantiti dan unit bagi tiang.*

[5 marks]

[5 markah]

CLO2

- (b) Based on Figure B4(b), determine the quantity for excavation work and concrete work for pad footing.  
*Berdasarkan Rajah B4(b), tentukan kuantiti untuk kerja penggalian dan kerja konkrit untuk asas tapak.*

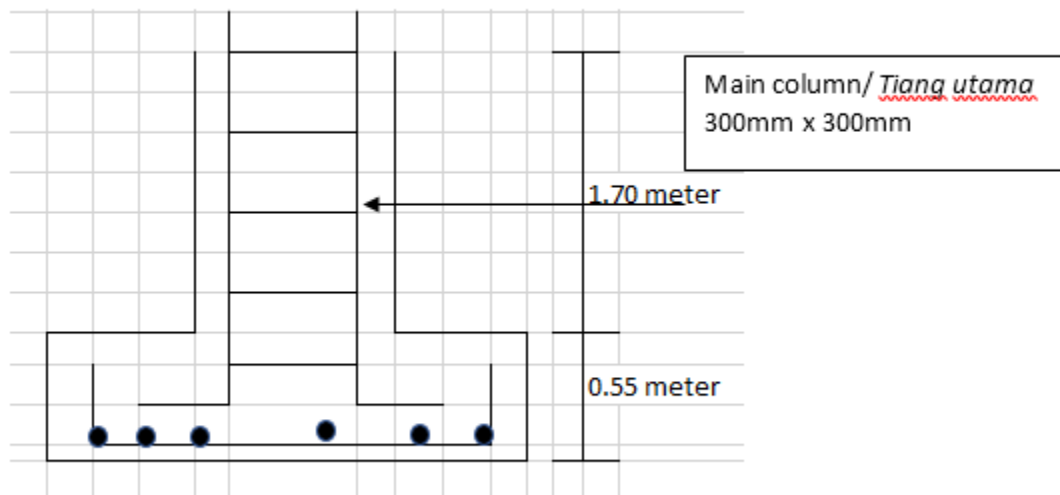

Figure B4(b) : Pad Footing / *Rajah B4(b) : Asas Tapak*

Data given / *Diberi data:*

Number of footing/ *Bil penapak* = 9

Size of footing/ *Saiz penapak* = 1200mm x 1200mm

Concrete ratio/ *Nisbah konkrit*: = 1:2:4

Lean concrete/ *Alas konkrit* = 50mm

[10 marks]

[10 markah]



DCC20073 – CONTRACT AND ESTIMATING  
DEPARTMENT OF CIVIL ENGINEERING

<b>Drawing No.:</b>	<b>Bill. No.:</b>	<b>Element:</b>	<b>Slip No.:</b> /
<b>Heading:</b>			<b>Unit:</b>
<b>Description:</b>			<b>Quantity:</b>

DCC20073 – CONTRACT AND ESTIMATING  
DEPARTMENT OF CIVIL ENGINEERING

<b>Drawing No.:</b>	<b>Bill. No.:</b>	<b>Element:</b>	<b>Slip No.:</b> /
<b>Heading:</b>			<b>Unit:</b>
<b>Description:</b>			<b>Quantity:</b>

DCC20073 – CONTRACT AND ESTIMATING  
DEPARTMENT OF CIVIL ENGINEERING

<b>Drawing No.:</b>	<b>Bill. No.:</b>	<b>Element:</b>	<b>Slip No.:</b> /
<b>Heading:</b>			<b>Unit:</b>
<b>Description:</b>			<b>Quantity:</b>

DCC20073 – CONTRACT AND ESTIMATING  
DEPARTMENT OF CIVIL ENGINEERING

<b>Drawing No.:</b>	<b>Bill. No.:</b>	<b>Element:</b>	<b>Slip No.:</b> /
<b>Heading:</b>			<b>Unit:</b>
<b>Description:</b>			<b>Quantity:</b>

DCC20073 – CONTRACT AND ESTIMATING  
DEPARTMENT OF CIVIL ENGINEERING

<b>Drawing No.:</b>	<b>Bill. No.:</b>	<b>Element:</b>	<b>Slip No.:</b> /
<b>Heading:</b>			<b>Unit:</b>
<b>Description:</b>			<b>Quantity:</b>



DCC20073 – CONTRACT AND ESTIMATING  
DEPARTMENT OF CIVIL ENGINEERING

<b>Drawing No.:</b>	<b>Bill. No.:</b>	<b>Element:</b>	<b>Slip No.:</b> /
<b>Heading:</b>			<b>Unit:</b>
<b>Description:</b>			<b>Quantity:</b>

DCC20073 – CONTRACT AND ESTIMATING  
DEPARTMENT OF CIVIL ENGINEERING

<b>Drawing No.:</b>	<b>Bill. No.:</b>	<b>Element:</b>	<b>Slip No.:</b> /
<b>Heading:</b>			<b>Unit:</b>
<b>Description:</b>			<b>Quantity:</b>

DCC20073 – CONTRACT AND ESTIMATING  
DEPARTMENT OF CIVIL ENGINEERING

<b>Drawing No.:</b>	<b>Bill. No.:</b>	<b>Element:</b>	<b>Slip No.:</b> /
<b>Heading:</b>			<b>Unit:</b>
<b>Description:</b>			<b>Quantity:</b>