

**SULIT**



**KEMENTERIAN PENDIDIKAN TINGGI  
JABATAN PENDIDIKAN POLITEKNIK DAN KOLEJ KOMUNITI**

**BAHAGIAN PEPERIKSAAN DAN PENILAIAN  
JABATAN PENDIDIKAN POLITEKNIK DAN KOLEJ KOMUNITI  
KEMENTERIAN PENDIDIKAN TINGGI**

**JABATAN KEJURUTERAAN ELEKTRIK**

**PEPERIKSAAN AKHIR**

**SESI I : 2023/2024**

**DET10013 : ELECTRICAL TECHNOLOGY**

**TARIKH : 2 JANUARI 2024**

**MASA : 11.15 AM – 1.15 PM (2 JAM)**

---

Kertas ini mengandungi **SEBELAS (11)** halaman bercetak.  
Bahagian A: Subjektif (4 soalan)  
Bahagian B: Esei (1 soalan)

Dokumen sokongan yang disertakan : Formula

---

**JANGAN BUKA KERTAS SOALAN INI SEHINGGA DIARAHKAN**

(CLO yang tertera hanya sebagai rujukan)

**SULIT**

**SECTION A : 80 MARKS**  
**BAHAGIAN A : 80 MARKAH**

**INSTRUCTION:**

This section consists of **FOUR (4)** subjective questions. Answer **ALL** questions.

**ARAHAN :**

*Bahagian ini mengandungi **EMPAT (4)** soalan subjektif. Jawab **SEMUA** soalan.*

**QUESTION 1**

**SOALAN 1**

- CLO1 (a) State **FOUR (4)** factors which will affect the value of resistance.

*Nyatakan **EMPAT (4)** faktor yang akan mempengaruhi nilai rintangan.*

[4 marks]

[4 markah]

- CLO1 (b) By referring to Figure A1(b)(i) and Figure A1(b)(ii), simplify the circuits to obtain the equivalent resistance value,  $R_T$ .

*Dengan merujuk kepada Rajah A1(b)(i) dan Rajah A1(b)(ii), permudahkan litar untuk mendapatkan nilai rintangan setara,  $R_T$ .*

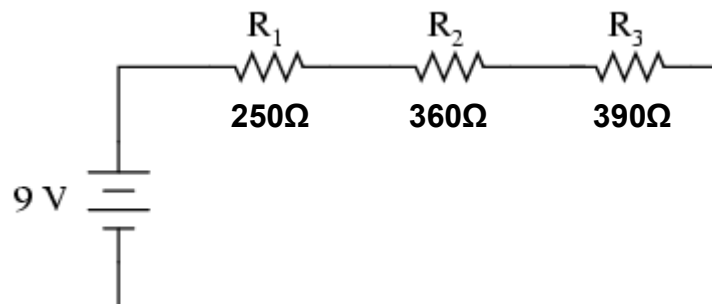

Figure A1(b)(i)/ Rajah A1(b)(i)

[3 marks]

[3 markah]

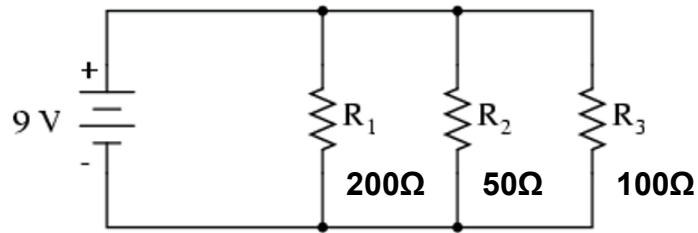

Figure A1(b)(ii)/ *Rajah A1(b)(ii)*

[3 marks]

[3 markah]

CLO1

(c) Based on the circuit shown in Figure A1(c), calculate the total resistance, the total current and the voltage drop across the resistor  $R_3$ .

*Berdasarkan litar yang ditunjukkan dalam Rajah A1(c), kirakan jumlah rintangan ( $R_T$ ), jumlah arus ( $I_T$ ) dan susut voltan merentasi perintang  $R_3$ .*

[10 marks]

[10 markah]

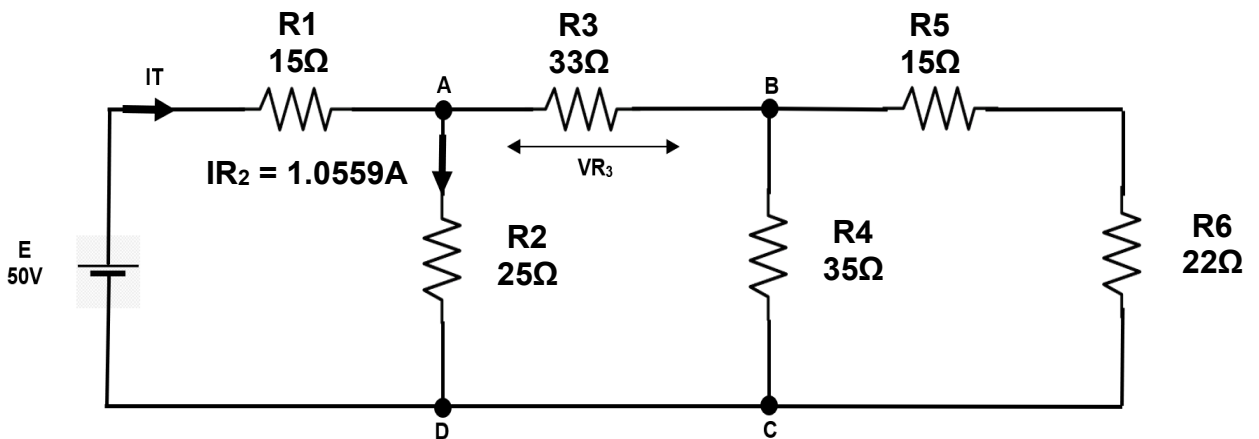

Figure A1(c) / *Rajah A1(c)*

## QUESTION 2

## SOALAN 2

- CLO1 (a) Define a capacitor and label the construction of a capacitor shown in Figure 2(a).  
*Takrifkan pemuat dan labelkan pembinaan pemuat seperti yang ditunjukkan dalam Rajah 2(a).*

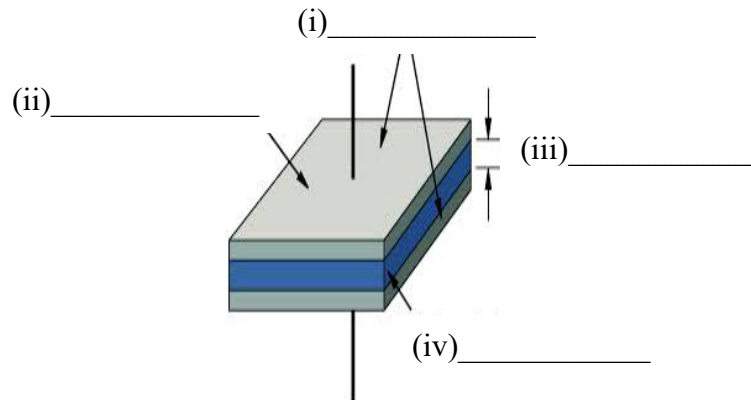

Figure 2(a) / Rajah 2(a)

[4 marks]

[4 markah]

- CLO1 (b) By referring to Figure A2(b), simplify the circuit to obtain the equivalent capacitance value,  $C_T$  at terminal A-B.  
*Dengan merujuk kepada Rajah A2(b), permudahkan litar untuk mendapatkan nilai kemuatan setara,  $C_T$  pada terminal A-B.*

[6 marks]

[6 markah]

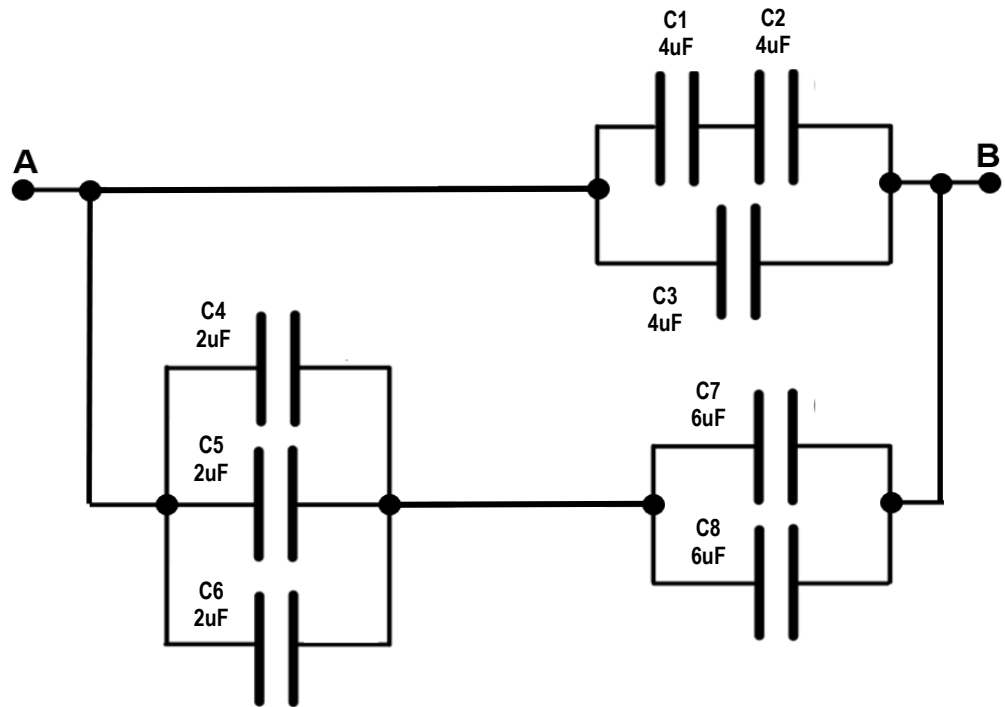

Figure A2(b) / Rajah A2(b)

CLO1

- (c) Figure A2(c) shows a schematic diagram that consists of resistive and capacitive loads. If the switch, SW is switched to node a at  $t = 0$ s, calculate the time constant, the instantaneous value of current when  $t = 2$ ms and the maximum energy stored by the capacitor.

*Rajah A2(c) menunjukkan rajah skematik yang terdiri daripada beban rintangan dan kapasitif. Jika suis, SW ditukar kepada nod a pada  $t = 0$ s, kirakan pemalar masa, nilai serta-merta arus apabila  $t = 2$ ms dan tenaga maksimum yang disimpan oleh kapasitor.*

[10 marks]

[10 markah]

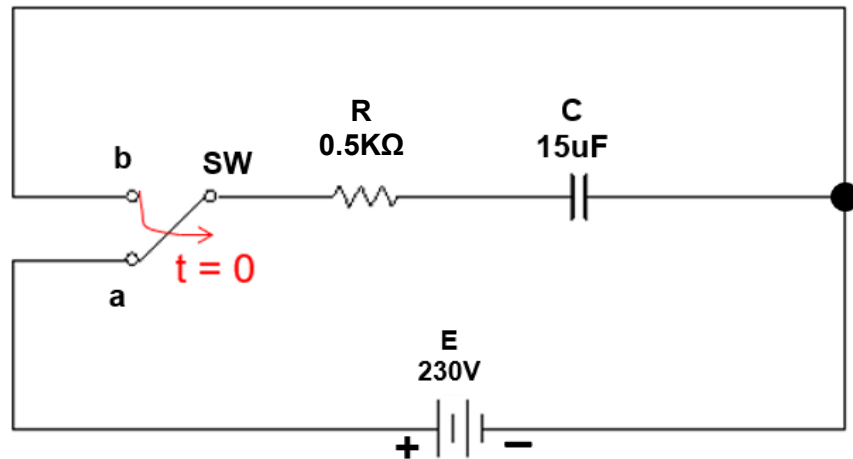

Figure A2(c) / Rajah A2(c)

## QUESTION 3

## SOALAN 3

CLO1

- (a) State
- FOUR (4)**
- factors that influence inductance.

*Nyatakan **EMPAT (4)** faktor yang mempengaruhi kearuhan.*

[4 marks]

[4 markah]

CLO1

- (b) By referring to Figure A3(b), simplify the circuit to obtain the equivalent inductance value (
- $L_T$
- ) at terminal A-B.

*Dengan merujuk kepada Rajah A3(b), permudahkan litar untuk mendapatkan nilai kearuhan setara ( $L_T$ ) pada terminal A-B.*

[6 marks]

[6 markah]

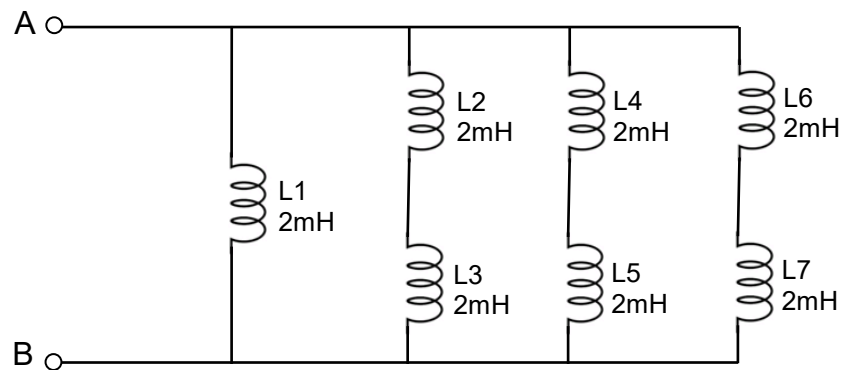
Figure A3(b) / *Rajah A3(b)*

[6 marks]

[6 markah]

CLO1

- (c) Referring to Figure A3(c), calculate the current in the inductor after the switch, SW1 is closed for  $30\mu\text{s}$  and the maximum energy stored by the inductor.

*Merujuk kepada Rajah A3(c), kirakan arus dalam peraruh selepas suis, SW1 ditutup selama  $30\mu\text{s}$  dan tenaga maksimum yang disimpan oleh peraruh.*

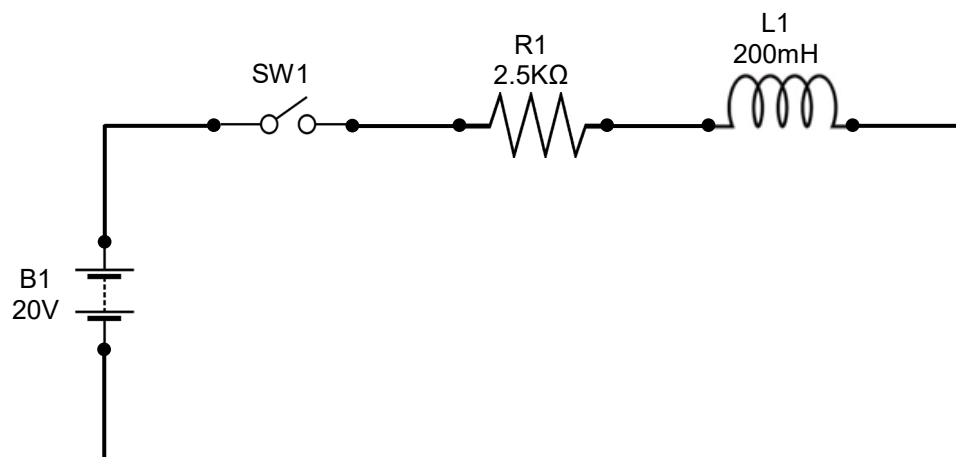
Figure A3(c) / *Rajah A3(c)*

[10 marks]

[10 markah]

## QUESTION 4

## SOALAN 4

- CLO1 (a) Trace the direction of magnetic flux formed by the couple of magnets shown in Figure 4(a)(i) and Figure 4(a)(ii).

*Surih arah fluks magnet yang terbentuk oleh pasangan magnet yang ditunjukkan dalam Rajah 4(a)(i) dan Rajah 4(a)(ii).*



Figure 4(a)(i) / Rajah 4(a)(i)

[2 marks]

[2 markah]



Figure 4(a)(ii) / Rajah 4(a)(ii)

[2 marks]

[2 markah]

- CLO1 (b) Explain the **THREE (3)** methods to determine the direction of magnetic flux formed by a current carrying conductor.

*Terangkan TIGA (3) kaedah untuk menentukan arah fluks magnet yang terbentuk oleh pengalir yang membawa arus.*

[6 marks]

[6 markah]



- CLO1 (c) Based on Figure A4(c) below, calculate the total resistance ( $R_T$ ) at terminal A-B by using delta-to-star transformation method.

*Berdasarkan Rajah A4(c) di bawah, kirakan jumlah rintangan ( $R_T$ ) pada terminal A-B dengan menggunakan kaedah transformasi delta-ke-bintang.*

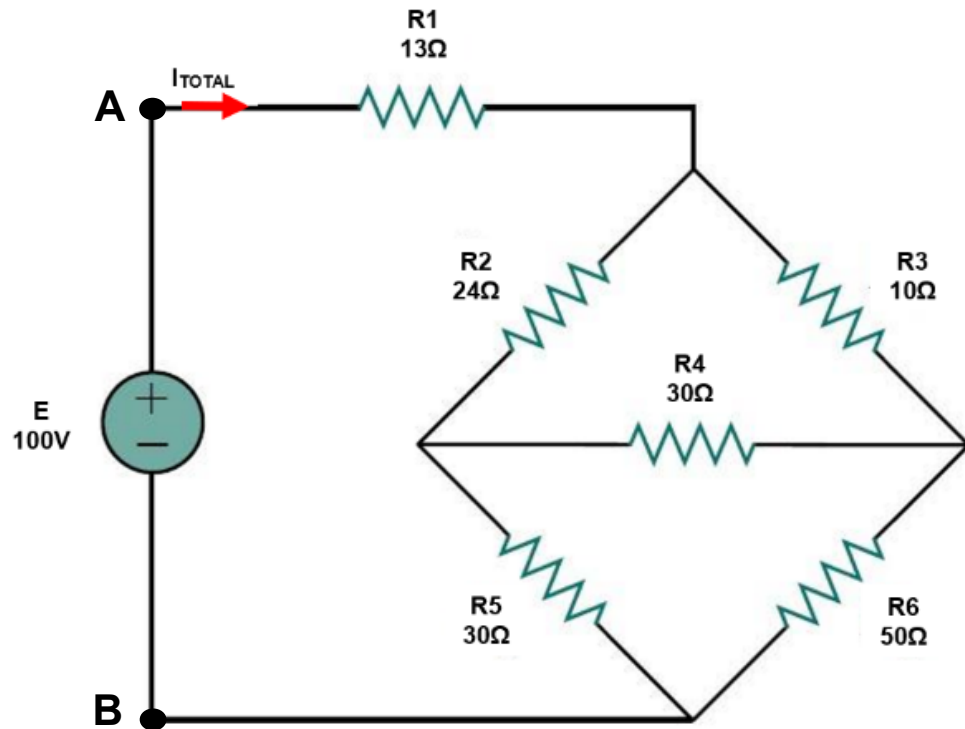

Figure A4(c)/ *Rajah A4(c)*

[10 marks]

[10 markah]

**SECTION B : 20 MARKS*****BAHAGIAN A : 20 MARKAH*****INSTRUCTION:**

This section consists of **ONE (1)** essay question. Answer the question.

***ARAHAN:***

*Bahagian ini mengandungi SATU (1) soalan esei. Jawab semua soalan.*

CLO1

**QUESTION 1*****SOALAN 1***

Figure B1 shows a series-parallel circuit. Kirchhoff's Current Law (KCL) states that total current entering a node is equal to the total current leaving that node. Kirchhoff's Voltage Law (KVL) states that in any closed loop, the sum of EMF applied is equal to the sum of all the voltage drops within the same loop. Thus, with the aid of a circuit diagram that includes current directions and loops, calculate the current flow through the resistors  $R_1$ ,  $R_2$ , and  $R_3$  by using Kirchhoff's Law method.

*Gambar rajah B1 menunjukkan satu litar siri-selari. Hukum Arus Kirchhoff (KCL) menyatakan bahawa jumlah arus yang memasuki satu nod adalah sama dengan jumlah arus yang meninggalkan nod tersebut. Hukum Voltan Kirchhoff (KVL) menyatakan bahawa dalam mana-mana gelung tertutup, jumlah EMF yang digunakan adalah sama dengan jumlah semua susut voltan dalam gelung yang sama. Oleh itu, dengan bantuan gambar rajah litar yang merangkumi arah arus dan gelung, kirakan arus yang mengalir melalui perintang  $R_1$ ,  $R_2$ , dan  $R_3$  dengan menggunakan kaedah Hukum Kirchhoff.*

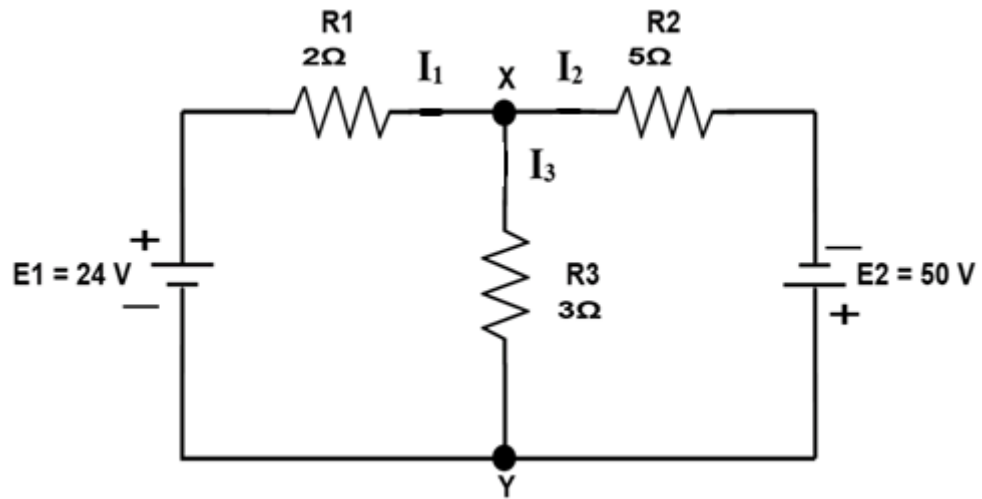
Figure B1 / *Rajah B1*

[20 marks]

[20 markah]

**SOALAN TAMAT**

FORMULA

1) $Q = It$	19) $P = IV$
2) $V = IR$	20) $R_T = \frac{1}{\frac{1}{R_1} + \frac{1}{R_2} + \dots + \frac{1}{R_n}}$
3) $R_T = R_1 + R_2 + \dots + R_n$	21) $C = \frac{Q}{V}$
4) $W = Pt$	22) $D = \frac{Q}{A}$
5) $E = \frac{V}{d}$	23) $\varepsilon = \varepsilon_0 \varepsilon_r = \frac{D}{E}$
6) $C = \frac{\varepsilon_r \varepsilon_0 A}{d}$	24) $\varepsilon_0 = 8.854 \times 10^{-12}$
7) $\tau = RC$	25) $E_C = \frac{1}{2} CV^2$
8) $v_C(t) = V_{max}(1 - e^{-t/\tau})$	26) $i_C(t) = I_{max}(e^{-t/\tau})$
9) $v_C(t) = V_{max}(e^{-t/\tau})$	27) $i_C(t) = -I_{max}(e^{-t/\tau})$
10) $E = -L \frac{dI}{dt}$	28) $E = -N \frac{d\phi}{dt}$
11) $L = \frac{N\phi}{I}$	29) $\tau = \frac{L}{R}$
12) $L = \frac{N^2 \mu_r \mu_0 A}{l}$	30) $\mu = \mu_0 \mu_r$
13) $i_L(t) = I_{max}(1 - e^{-t/\tau})$	31) $\mu_0 = 4\pi \times 10^{-7}$
14) $i_L(t) = I_{max}(e^{-t/\tau})$	32) $E_L = \frac{1}{2} LI^2$
15) $F_m = IN$	33) $H = \frac{F_m}{l}$
16) $B = \frac{\phi}{A}$	34) $S = \frac{F_m}{\phi}$
17) $\mu = \frac{B}{H}$	35) $S = \frac{l}{\mu_0 \mu_r A}$
18) $R = \frac{\rho l}{A}$	