

**SULIT**



**KEMENTERIAN PENDIDIKAN TINGGI  
JABATAN PENDIDIKAN POLITEKNIK DAN KOLEJ KOMUNITI**

**BAHAGIAN PEPERIKSAAN DAN PENILAIAN  
JABATAN PENDIDIKAN POLITEKNIK DAN KOLEJ KOMUNITI  
KEMENTERIAN PENDIDIKAN TINGGI**

**JABATAN KEJURUTERAAN ELEKTRIK**

**PEPERIKSAAN AKHIR**

**SESI II : 2023/2024**

**DEC40053: EMBEDDED SYSTEM AND APPLICATIONS**

**TARIKH : 14 JUN 2024**

**MASA : 8.30 AM – 10.30 AM (2 JAM)**

---

Kertas ini mengandungi **LIMA BELAS (15)** halaman bercetak.

Bahagian A: Subjektif (3 soalan)

Bahagian B: Esei (2 soalan)

Dokumen sokongan yang disertakan : Lampiran

---

**JANGAN BUKA KERTAS SOALAN INI SEHINGGA DIARAHKAN**

(CLO yang tertera hanya sebagai rujukan)

**SULIT**

**SECTION A : 60 MARKS****BAHAGIAN A : 60 MARKAH****INSTRUCTION:**

This section consists of **(3)** subjective questions. Answer ALL questions.

**ARAHAN :**

*Bahagian ini mengandungi **TIGA (3)** soalan subjektif. Jawab **SEMUA** soalan.*

**QUESTION 1****SOALAN 1**

CLO1

- (a) Discuss **TWO (2)** differences between microcontrollers and microprocessors.

*Bincangkan **DUA (2)** perbezaan antara mikropengawal dan mikropemproses*

[4 marks]

[4 markah]

CLO1

- (b) A programmer decided to make controlling two devices of two LEDs, one LCD and one buzzer. These electronic devices were controlled by one micro switch and three digital sensors. Write an instruction using the C program to configure the pins used as I/O using bit addressable mode. Assume LED uses Port A, LCD uses Port B, the buzzer uses Port C, the micro switch uses Port D, and the sensor uses Port E.

*Seorang pengaturcara memutuskan untuk membuat peranti mengawal dua LED, satu LCD dan satu buzzer. Peranti elektronik ini dikawal oleh satu suis mikro dan tiga sensor digital. Tulis arahan menggunakan program C untuk mengkonfigurasi pin yang digunakan sebagai I/O menggunakan mod pengalamatan bit. Andaikan LED menggunakan Port A, LCD menggunakan Port B, buzzer menggunakan Port C, suis mikro menggunakan Port D, dan sensor menggunakan Port E.*

[8 marks]

[8 markah]

CLO1

- (c) Timer 0 in PIC18 operates with a crystal oscillator frequency of 64 MHz. The configuration is T0CON set to 0x07 and TMR0H: TMR0L set to D5A8. Calculate the time delay generated by this timer is based on the provided information and the maximum time delay for this timer. Use Appendix A1 as reference.

*Pemasa 0 dalam PIC18 beroperasi dengan frekuensi pengayun kristal 64 MHz. Konfigurasi ialah T0CON ditetapkan kepada 0x07 dan TMR0H:TMR0L ditetapkan kepada D5A8. Kira lengah masa yang dijana oleh pemasa ini berdasarkan maklumat yang diberikan dan masa maksimum untuk pemasa ini. Gunakan Lampiran A1 sebagai rujukan*

[8 marks]

[8 markah]

**QUESTION 2****SOALAN 2**

CLO1

- (a) Explain the operation of TMR0L and TMR0H in PIC18 with a suitable example.

*Terangkan operasi TMR0L dan TMR0H dalam PIC18 dengan contoh yang sesuai.*

[4 marks]

[4 markah]

CLO1

- (b) Write a C instruction for a PIC18 microcontroller with an external hardware interrupt (INT0 active low) for a machine by using a proximity sensor to detect movement. When a movement is detected, the machine should be immediately stopped. An emergency lamp connected to RB1 should also be activated for alarm purposes. Use RB0 for the proximity sensor and RB1 for the Emergency Lamp. Use Appendix A2 to A3 as references.

*Tulis arahan C untuk mikropengawal PIC18 dengan gangguan perkakasan luaran (INT0 active low) untuk mesin yang menggunakan sensor jarak untuk mengesan pergerakan. Apabila pergerakan dikesan, mesin harus segera dihentikan. Selain itu, lampu kecemasan yang disambungkan kepada RB1 harus diaktifkan untuk tujuan penggera. Gunakan RB0 untuk penderia jarak dan RB1 untuk lampu kecemasan. Guna lampiran A2 ke A3 sebagai rujukan*

[8 marks]

[8 markah]

CLO1

- (c) Provide “comment” for each line of the C program in Figure A2 (c), with the input device being a switch and the output device being an LED.

*Sediakan “komen” untuk setiap baris program C dalam Rajah A2(c), dengan peranti input sebagai suis dan peranti output sebagai LED*

[8 marks]

[8 markah]

```
#include<xc.h>
#define LED LATCbits.LATC6
void main (void)
{
    ADCON1=0x0F;
    TRISBbits.TRISB0 = 1;
    TRIScbits.TRISC6 = 0;
    INTCONbits.INT0IF = 0;
    INTCONbits.INT0IE = 1;
    INTCONbits.GIE = 1;
    while(1) {
    }
}
static void interrupt isr (void) {
    if (INTCONbits.INT0IF == 1) {
        LED = PORTBbits.RB0;
        INTCONbits.INT0IF = 0;
    }
}
```

Figure A2 (c) / Rajah A2 (c)

**QUESTION 3****SOALAN 3**

- CLO1 (a) Discuss the function of TMR0IF (TMR0 Interrupt Flag) in Timer 0 for 8-bit and 16-bit operations.  
*Bincangkan fungsi TMR0IF (TMR0 Interrupt Flag) dalam Pemasa 0 untuk 8 operasi bit dan 16 bit.*
- [5 marks]  
[5 markah]
- CLO1 (b) Explain the Analogue-to-Digital Converter (ADC) programming steps for PIC16F/18F.  
*Terangkan langkah pengaturcaraan Analog-to-Digital Converter (ADC) untuk PIC16F/18F.*
- [5 marks]  
[5 markah]
- CLO1 (c) Referring to Figure A3 (b), a 10-bit ADC module inside PIC18 converts analog signal from channel AN0. Carry out the values of ADCON0, ADCON1 and the digital output, Dout, if both Vref are taken from the external pin and the value of the AN0 is 0.5 volts. Use appendix A4 to A6 as references.  
(Given the  $V_{REF+} = 2.8V$ ,  $V_{REF-} = 1.4V$ )
- Merujuk kepada Rajah A3 (b), modul ADC 10-bit di dalam PIC18 digunakan untuk menukar isyarat analog daripada saluran AN0. Tentukan nilai untuk ADCON0, ADCON1 dan output digital, Dout, jika kedua-dua Vref diambil dari pin luaran dan nilai AN0 ialah 0.5 volt. Guna lampiran A4 ke A6 sebagai rujukan.*

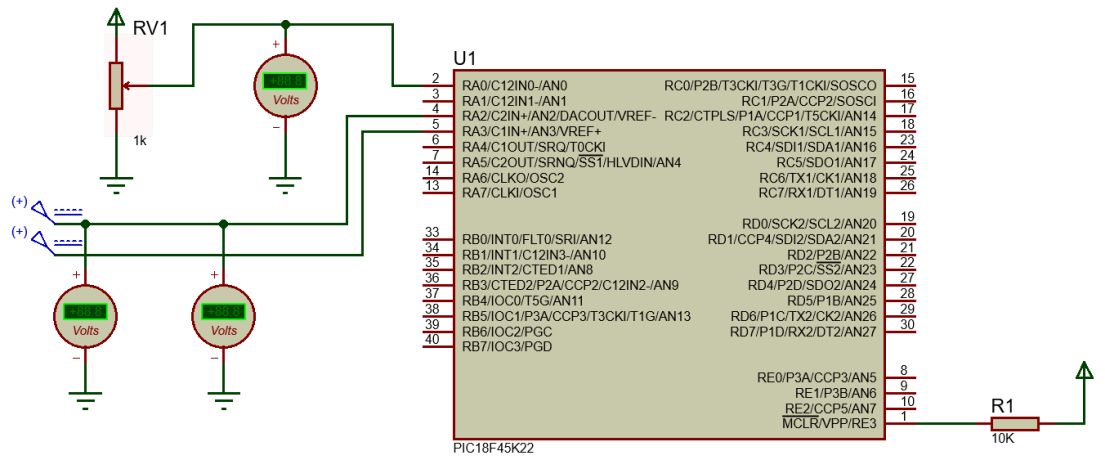

Figure A3 (b) / *Rajah A3 (b)*

[10 marks]

[10 markah]

**SECTION B : 40 MARKS****BAHAGIAN B : 40 MARKAH****INSTRUCTION:**

This section consists of **TWO (2)** essay questions. Answer the question.

**ARAHAN:**

*Bahagian ini mengandungi **DUA (2)** soalan esei. Jawab semua soalan ini.*

**QUESTION 1****SOALAN 1**

CLO1

The production process supervisor at a beverage manufacturing facility wants to use a green LED indication on the control panel. This indication will appear when both containers have reached a capacity exceeding one-fourth. If PIC18F microcontroller replaces the NAND gate as in figure B1, write C program for this production process. The LED will turn on once containers A and B exceed a quarter of their total capacity.

*Penyelia proses pengeluaran di kemudahan pembuatan minuman ingin menggunakan petunjuk LED hijau pada panel kawalan. Petunjuk ini akan muncul apabila kedua-dua bekas telah mencapai kapasiti melebihi satu perempat. Jika mikropengawal PIC18F digunakan untuk menggantikan get NAND seperti rajah B1. Tulis C program untuk proses produksi tersebut. LED akan dihidupkan apabila bekas A dan B melebihi satu perempat daripada jumlah kapasitinya.*

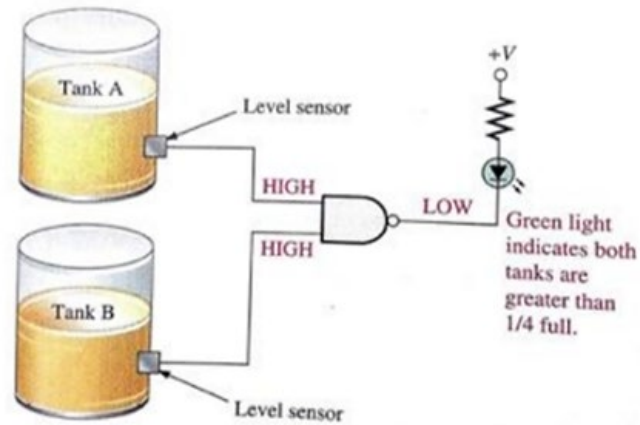
Figure B1 / *Rajah B1*

[20 Marks]

[20Markah]

**QUESTION 2****SOALAN 2**

CLO2

You have been tasked with developing a program for an "AUTOMATED PLANT WATERING SYSTEM" project using the C program. The project requires port B as the input and port C as the output in PIC18. The specific operations that the software must include are shown in Table B2.

Table B2 / *Jadual B2*

Input (Port B)	Output (Port C)
Sensor Data	Watering Control

According to the table, develop a program that efficiently processes sensor data from port B and controls the automated watering system through port C.



*Anda telah ditugaskan untuk program untuk projek " AUTOMATED PLANT WATERING SYSTEM " menggunakan program C. Projek ini memerlukan port B sebagai input dan port C sebagai output dalam PIC18. Operasi khusus yang mesti disertakan oleh perisian ditunjukkan dalam Jadual B2. Dengan merujuk jadual, bangunkan dan laksanakan program yang memproses data penderia dengan cekap dari port B dan mengawal sistem penyiraman automatik melalui port C.*

[20 Marks]

[20Markah]

### SOALAN TAMAT

## APPENDIX A1 / LAMPIRAN A1

REGISTER 11-1: T0CON: TIMER0 CONTROL REGISTER

R/W-1	R/W-1	R/W-1	R/W-1	R/W-1	R/W-1	R/W-1	R/W-1
TMR0ON	T08BIT	T0CS	T0SE	PSA	T0PS2	T0PS1	T0PS0
bit 7							bit 0

**Legend:**

R = Readable bit  
-n = Value at POR

W = Writable bit  
'1' = Bit is set

U = Unimplemented bit, read as '0'  
'0' = Bit is cleared  
x = Bit is unknown

- bit 7      **TMR0ON:** Timer0 On/Off Control bit  
1 = Enables Timer0  
0 = Stops Timer0
- bit 6      **T08BIT:** Timer0 8-Bit/16-Bit Control bit  
1 = Timer0 is configured as an 8-bit timer/counter  
0 = Timer0 is configured as a 16-bit timer/counter
- bit 5      **T0CS:** Timer0 Clock Source Select bit  
1 = Transition on T0CKI pin  
0 = Internal instruction cycle clock (CLKO)
- bit 4      **T0SE:** Timer0 Source Edge Select bit  
1 = Increment on high-to-low transition on T0CKI pin  
0 = Increment on low-to-high transition on T0CKI pin
- bit 3      **PSA:** Timer0 Prescaler Assignment bit  
1 = Timer0 prescaler is NOT assigned. Timer0 clock input bypasses prescaler.  
0 = Timer0 prescaler is assigned. Timer0 clock input comes from prescaler output.
- bit 2-0    **T0PS2:T0PS0:** Timer0 Prescaler Select bits  
111 = 1:256 Prescale value  
110 = 1:128 Prescale value  
101 = 1:64 Prescale value  
100 = 1:32 Prescale value  
011 = 1:16 Prescale value  
010 = 1:8 Prescale value  
001 = 1:4 Prescale value  
000 = 1:2 Prescale value

$$T_{CY} = \frac{1}{F_{osc} \div 4 \div PRESCALER}$$

## APPENDIX A2 / LAMPIRAN A2

**REGISTER 9-1: INTCON: INTERRUPT CONTROL REGISTER**

R/W-0	R/W-0	R/W-0	R/W-0	R/W-0	R/W-0	R/W-0	R/W-x
GIE/GIEH	PEIE/GIEL	TMR0IE	INT0IE	RBIE	TMR0IF	INT0IF	RBIF <sup>(1)</sup>
bit 7							bit 0

**Legend:**

R = Readable bit                      W = Writable bit                      U = Unimplemented bit, read as '0'  
 -n = Value at POR                      '1' = Bit is set                      '0' = Bit is cleared                      x = Bit is unknown

- bit 7                      **GIE/GIEH:** Global Interrupt Enable bit  
When IPEN = 0:  
 1 = Enables all unmasked interrupts  
 0 = Disables all interrupts  
When IPEN = 1:  
 1 = Enables all high priority interrupts  
 0 = Disables all high priority interrupts
- bit 6                      **PEIE/GIEL:** Peripheral Interrupt Enable bit  
When IPEN = 0:  
 1 = Enables all unmasked peripheral interrupts  
 0 = Disables all peripheral interrupts  
When IPEN = 1:  
 1 = Enables all low priority peripheral interrupts  
 0 = Disables all low priority peripheral interrupts
- bit 5                      **TMR0IE:** TMR0 Overflow Interrupt Enable bit  
 1 = Enables the TMR0 overflow interrupt  
 0 = Disables the TMR0 overflow interrupt
- bit 4                      **INT0IE:** INT0 External Interrupt Enable bit  
 1 = Enables the INT0 external interrupt  
 0 = Disables the INT0 external interrupt
- bit 3                      **RBIE:** RB Port Change Interrupt Enable bit  
 1 = Enables the RB port change interrupt  
 0 = Disables the RB port change interrupt
- bit 2                      **TMR0IF:** TMR0 Overflow Interrupt Flag bit  
 1 = TMR0 register has overflowed (must be cleared in software)  
 0 = TMR0 register did not overflow
- bit 1                      **INT0IF:** INT0 External Interrupt Flag bit  
 1 = The INT0 external interrupt occurred (must be cleared in software)  
 0 = The INT0 external interrupt did not occur
- bit 0                      **RBIF:** RB Port Change Interrupt Flag bit<sup>(1)</sup>  
 1 = At least one of the RB7:RB4 pins changed state (must be cleared in software)  
 0 = None of the RB7:RB4 pins have changed state

**Note 1:** A mismatch condition will continue to set this bit. Reading PORTB will end the mismatch condition and allow the bit to be cleared.

## APPENDIX A3 / LAMPIRAN A3

**REGISTER 9-2: INTCON2: INTERRUPT CONTROL REGISTER 2**

R/W-1	R/W-1	R/W-1	R/W-1	U-0	R/W-1	U-0	R/W-1
RBPUP	INTEDG0	INTEDG1	INTEDG2	—	TMR0IP	—	RBIP
bit 7							bit 0

**Legend:**

R = Readable bit	W = Writable bit	U = Unimplemented bit, read as '0'
-n = Value at POR	'1' = Bit is set	'0' = Bit is cleared
		x = Bit is unknown

- bit 7      **RBPUP**: PORTB Pull-up Enable bit  
1 = All PORTB pull-ups are disabled  
0 = PORTB pull-ups are enabled by individual port latch values
- bit 6      **INTEDG0**: External Interrupt 0 Edge Select bit  
1 = Interrupt on rising edge  
0 = Interrupt on falling edge
- bit 5      **INTEDG1**: External Interrupt 1 Edge Select bit  
1 = Interrupt on rising edge  
0 = Interrupt on falling edge
- bit 4      **INTEDG2**: External Interrupt 2 Edge Select bit  
1 = Interrupt on rising edge  
0 = Interrupt on falling edge
- bit 3      **Unimplemented**: Read as '0'
- bit 2      **TMR0IP**: TMR0 Overflow Interrupt Priority bit  
1 = High priority  
0 = Low priority
- bit 1      **Unimplemented**: Read as '0'
- bit 0      **RBIP**: RB Port Change Interrupt Priority bit  
1 = High priority  
0 = Low priority

## APPENDIX A4 / LAMPIRAN A4

## REGISTER 21-1: ADCON0: A/D CONTROL REGISTER 0

U-0	U-0	R/W-0	R/W-0	R/W-0	R/W-0	R/W-0	R/W-0
—	—	CHS3	CHS2	CHS1	CHS0	GO/DONE	ADON
bit 7						bit 0	

**Legend:**

R = Readable bit

W = Writable bit

U = Unimplemented bit, read as '0'

-n = Value at POR

'1' = Bit is set

'0' = Bit is cleared

x = Bit is unknown

bit 7-6 **Unimplemented:** Read as '0'bit 5-2 **CHS3:CHS0:** Analog Channel Select bits

0000 = Channel 0 (AN0)  
 0001 = Channel 1 (AN1)  
 0010 = Channel 2 (AN2)  
 0011 = Channel 3 (AN3)  
 0100 = Channel 4 (AN4)  
 0101 = Channel 5 (AN5)<sup>(1,2)</sup>  
 0110 = Channel 6 (AN6)<sup>(1,2)</sup>  
 0111 = Channel 7 (AN7)<sup>(1,2)</sup>  
 1000 = Channel 8 (AN8)  
 1001 = Channel 9 (AN9)  
 1010 = Channel 10 (AN10)  
 1011 = Channel 11 (AN11)  
 1100 = Channel 12 (AN12)  
 1101 = Unimplemented<sup>(2)</sup>  
 1110 = Unimplemented<sup>(2)</sup>  
 1111 = Unimplemented<sup>(2)</sup>

bit 1 **GO/DONE:** A/D Conversion Status bitWhen ADON = 1:

1 = A/D conversion in progress

0 = A/D Idle

bit 0 **ADON:** A/D On bit

1 = A/D converter module is enabled

0 = A/D converter module is disabled

APPENDIX A5 / LAMPIRAN A5

REGISTER 21-2: ADCON1: A/D CONTROL REGISTER 1

U-0	U-0	R/W-0	R/W-0	R/W-0 <sup>(1)</sup>	R/W <sup>(1)</sup>	R/W <sup>(1)</sup>	R/W <sup>(1)</sup>
—	—	VCFG0	VCFG0	PCFG3	PCFG2	PCFG1	PCFG0
bit 7							bit 0

**Legend:**  
 R = Readable bit                      W = Writable bit                      U = Unimplemented bit, read as '0'  
 -n = Value at POR                      '1' = Bit is set                      '0' = Bit is cleared                      x = Bit is unknown

- bit 7-6                      **Unimplemented:** Read as '0'
- bit 5                      **VCFG0:** Voltage Reference Configuration bit (VREF- source)  
 1 = VREF- (AN2)  
 0 = VSS
- bit 4                      **VCFG0:** Voltage Reference Configuration bit (VREF+ source)  
 1 = VREF+ (AN3)  
 0 = VDD
- bit 3-0                      **PCFG3:PCFG0:** A/D Port Configuration Control bits:

PCFG3: PCFG0	AN12	AN11	AN10	AN9	AN8	AN7 <sup>(2)</sup>	AN6 <sup>(2)</sup>	AN5 <sup>(2)</sup>	AN4	AN3	AN2	AN1	AN0
0000 <sup>(1)</sup>	A	A	A	A	A	A	A	A	A	A	A	A	A
0001	A	A	A	A	A	A	A	A	A	A	A	A	A
0010	A	A	A	A	A	A	A	A	A	A	A	A	A
0011	D	A	A	A	A	A	A	A	A	A	A	A	A
0100	D	D	A	A	A	A	A	A	A	A	A	A	A
0101	D	D	D	A	A	A	A	A	A	A	A	A	A
0110	D	D	D	D	A	A	A	A	A	A	A	A	A
0111 <sup>(1)</sup>	D	D	D	D	D	A	A	A	A	A	A	A	A
1000	D	D	D	D	D	D	A	A	A	A	A	A	A
1001	D	D	D	D	D	D	D	A	A	A	A	A	A
1010	D	D	D	D	D	D	D	D	A	A	A	A	A
1011	D	D	D	D	D	D	D	D	D	A	A	A	A
1100	D	D	D	D	D	D	D	D	D	D	A	A	A
1101	D	D	D	D	D	D	D	D	D	D	D	A	A
1110	D	D	D	D	D	D	D	D	D	D	D	D	A
1111	D	D	D	D	D	D	D	D	D	D	D	D	D

A = Analog input                      D = Digital I/O

## APPENDIX A6 / LAMPIRAN A6

## REGISTER 21-3: ADCON2: A/D CONTROL REGISTER 2

R/W-0	U-0	R/W-0	R/W-0	R/W-0	R/W-0	R/W-0	R/W-0
ADFM	—	ACQT2	ACQT1	ACQT0	ADCS2	ADCS1	ADCS0
bit 7							bit 0

**Legend:**

R = Readable bit                      W = Writable bit                      U = Unimplemented bit, read as '0'  
 -n = Value at POR                      '1' = Bit is set                      '0' = Bit is cleared                      x = Bit is unknown

- bit 7                      **ADFM:** A/D Result Format Select bit  
 1 = Right justified  
 0 = Left justified
- bit 6                      **Unimplemented:** Read as '0'
- bit 5-3                      **ACQT2:ACQT0:** A/D Acquisition Time Select bits  
 111 = 20 TAD  
 110 = 16 TAD  
 101 = 12 TAD  
 100 = 8 TAD  
 011 = 6 TAD  
 010 = 4 TAD  
 001 = 2 TAD  
 000 = 0 TAD<sup>(1)</sup>
- bit 2-0                      **ADCS2:ADCS0:** A/D Conversion Clock Select bits  
 111 = FRC (clock derived from A/D RC oscillator)<sup>(1)</sup>  
 110 = FOSC/64  
 101 = FOSC/16  
 100 = FOSC/4  
 011 = FRC (clock derived from A/D RC oscillator)<sup>(1)</sup>  
 010 = FOSC/32  
 001 = FOSC/8  
 000 = FOSC/2

**Note 1:** If the A/D FRC clock source is selected, a delay of one T<sub>cy</sub> (instruction cycle) is added before the A/D clock starts. This allows the SLEEP instruction to be executed before starting a conversion.

TABLE 28-29: A/D CONVERSION REQUIREMENTS

Param No.	Symbol	Characteristic	Min	Max	Units	Conditions	
130	TAD	A/D Clock Period	PIC18FXXXX	0.7	25.0 <sup>(1)</sup>	μs	T <sub>OSC</sub> based, V <sub>REF</sub> ≥ 3.0V
			PIC18LFXXXX	1.4	25.0 <sup>(1)</sup>	μs	V <sub>DD</sub> = 2.0V, T <sub>OSC</sub> based, V <sub>REF</sub> full range
			PIC18FXXXX	TBD	1	μs	A/D RC mode
			PIC18LFXXXX	TBD	3	μs	V <sub>DD</sub> = 2.0V, A/D RC mode
131	TCNV	Conversion Time (not including acquisition time) <sup>(2)</sup>	11	12	TAD		
132	TACQ	Acquisition Time <sup>(3)</sup>	1.4 TBD	— —	μs μs	-40°C to +85°C 0°C ≤ to ≤ +85°C	
135	Tswc	Switching Time from Convert → Sample	—	(Note 4)			
137	Tdis	Discharge Time	0.2	—	μs		

**Legend:** TBD = To Be Determined

- Note 1:** The time of the A/D clock period is dependent on the device frequency and the TAD clock divider.  
**2:** ADRES registers may be read on the following T<sub>cy</sub> cycle.  
**3:** The time for the holding capacitor to acquire the "New" input voltage when the voltage changes full scale after the conversion (V<sub>DD</sub> to V<sub>SS</sub> or V<sub>SS</sub> to V<sub>DD</sub>). The source impedance (R<sub>S</sub>) on the input channels is 50Ω.  
**4:** On the following cycle of the device clock.