

SULIT



**KEMENTERIAN PENDIDIKAN TINGGI
JABATAN PENDIDIKAN POLITEKNIK DAN KOLEJ KOMUNITI**

**BAHAGIAN PEPERIKSAAN DAN PENILAIAN
JABATAN PENDIDIKAN POLITEKNIK DAN KOLEJ KOMUNITI
KEMENTERIAN PENDIDIKAN TINGGI**

JABATAN KEJURUTERAAN AWAM

PEPERIKSAAN AKHIR

SESI II : 2023/2024

DCW50222 : TIMBER TRADE

TARIKH : 27 MEI 2024

MASA : 2.30 PETANG - 4.30 PETANG (2 JAM)

Kertas ini mengandungi **LAPAN (8)** halaman bercetak.

Bahagian A : Struktur (2 soalan)

Bahagian B : Struktur (4 soalan)

Dokumen sokongan yang disertakan : Lampiran A

JANGAN BUKA KERTAS SOALAN INI SEHINGGA DIARAHKAN

(CLO yang tertera hanya sebagai rujukan)

SULIT

SECTION A: 50 MARKS***BAHAGIAN A: 50 MARKAH*****INSTRUCTION:**

This section consists of **TWO (2)** structured questions. Answer **ALL** questions.

ARAHAN:

Bahagian ini mengandungi DUA (2) soalan berstruktur. Jawab SEMUA soalan.

QUESTION 1***SOALAN 1***

- CLO1 (a) Identify **FIVE (5)** functions of Malaysian Timber Industry Board (MTIB).
Kenal pasti LIMA (5) peranan Lembaga Perindustrian Kayu Malaysia (MTIB).
[5 marks]
[5 markah]
- CLO1 (b) While Malaysia receives a good score to facilitate cross-border trade, the government still creates barriers to its goal of becoming a free and open market. Describe the trade barriers such as tariffs, quotas, and embargoes.
Walaupun Malaysia menerima skor yang baik untuk memudahkan perdagangan rentas sempadan, kerajaan masih mewujudkan halangan kepada matlamatnya untuk menjadi pasaran bebas dan terbuka. Huraikan halangan perdagangan seperti tarif, kuota, dan sekatan.
[10 marks]
[10 markah]
- CLO1 (c) International trade is crucial because countries rely on other countries to import goods which are not readily available in their own countries. Based on this statement, explain **FIVE (5)** components or parties involved in ensuring international trade functions smoothly.
Perdagangan antarabangsa adalah penting kerana negara bergantung kepada negara lain untuk mengimport barangan yang tidak tersedia di negara mereka

sendiri. Berdasarkan pernyataan ini, terangkan LIMA (5) komponen atau pihak yang terlibat dalam memastikan perdagangan antarabangsa berfungsi dengan lancar.

[10 marks]

[10 markah]

QUESTION 2

SOALAN 2

- CLO1 (a) Identify the roles of an agent in international trade.
Kenal pasti peranan ejen dalam perdagangan antarabangsa.
- [5 marks]
[5 markah]
- CLO1 (b) Identify the equipment used by the timber grader for the timber grading procedure.
Kenal pasti peralatan yang digunakan oleh pengred kayu untuk prosedur penggredan kayu.
- [10 marks]
[10 markah]
- CLO1 (c) The public considers Malaysia's timber industry as labor-intensive, dominated by foreign workers, and unsustainable in the long run. Based on this statement, explain the issue of foreign workers and the sustainability of wood supply which affects the wood trade in Malaysia.
Orang ramai menganggap industri perkayuan Malaysia sebagai intensif buruh, didominasi oleh pekerja asing, dan tidak mampan dalam jangka masa panjang. Berdasarkan pernyataan ini, terangkan isu pekerja asing dan kelestarian bekalan kayu yang menjejaskan perdagangan kayu di Malaysia.
- [10 marks]
[10 markah]

SECTION B: 50 MARKS***BAHAGIAN B: 50 MARKAH*****INSTRUCTION:**

This section consists of **FOUR (4)** structured questions. Answer **TWO (2)** questions only.

ARAHAN:

Bahagian ini mengandungi EMPAT (4) soalan berstruktur. Jawab DUA (2) soalan sahaja.

QUESTION 1***SOALAN 1***

- CLO1 (a) Describe the meaning of trade.
Huraikan maksud perdagangan.
- [5 marks]
[5 markah]
- CLO1 (b) As a businessman, you may rely on individuals and organizations involved in moving a product or service from the producer to the client. Referring to this statement, explain the trade distribution channel.
Sebagai ahli perniagaan, anda mungkin bergantung pada individu dan organisasi yang terlibat dalam menggerakkan produk atau perkhidmatan daripada pengeluar kepada pelanggan. Merujuk kepada kenyataan ini, terangkan saluran pengedaran perdagangan.
- [10 marks]
[10 markah]

- CLO1 (c) Explain the role of the Malaysian Timber Council (MTC) and the Malaysia External Trade Development Corporation (MATRADE) as the leading agencies for the timber industry in Malaysia.

Terangkan peranan Majlis Perkayuan Malaysia (MTC) dan Perbadanan Pembangunan Perdagangan Luar Malaysia (MATRADE) sebagai agensi peneraju industri perkayuan di Malaysia.

[10 marks]

[10 markah]

QUESTION 2

SOALAN 2

- CLO1 (a) Identify the first **FIVE (5)** import procedures.

Kenal pasti LIMA (5) prosedur import pertama.

[5 marks]

[5 markah]

- CLO1 (b) The export procedure is an international business operation that encompasses all of the steps which a company must take in order to sell its goods or products outside the borders of the country in which it operates. Determine the export procedure that you will use as an exporter.

Prosedur eksport ialah operasi perniagaan antarabangsa yang merangkumi semua langkah yang perlu diambil oleh syarikat untuk menjual barangan atau produknya di luar sempadan negara tempat syarikat beroperasi. Tentukan prosedur eksport yang akan anda gunakan sebagai pengeksport.

[10 marks]

[10 markah]

- CLO1 (c) The International Chamber of Commerce's (ICC) Incoterms are a set of 11 rules which explain the responsibilities of sellers and buyers in international product sales transactions. Write **FOUR (4)** groups of Incoterms in terms of location delivery.

*Incoterms Dewan Perniagaan Antarabangsa (ICC) ialah satu set 11 peraturan yang menerangkan tanggungjawab penjual dan pembeli dalam urus niaga jualan produk antarabangsa. Tuliskan **EMPAT (4)** kumpulan Incoterms mengikut terma lokasi penghantaran.*

[10 marks]

[10 markah]

QUESTION 3

SOALAN 3

- CLO1 (a) Identify grades and grade marks of wood in General Market Specifications (GMS).

Kenal pasti gred dan simbol gred kayu bagi Spesifikasi Pasaran Umum (GMS).

[5 marks]

[5 markah]

- CLO1 (b) General Market Specifications (GMS) are for grading boards and planks which usually re-sawn before being used for a wide variety of purposes. Explain the general requirement which applies in GMS.

Spesifikasi Pasaran Umum (GMS) adalah untuk mengred kayu dan papan yang lazimnya di gergaji semula sebelum ianya digunakan untuk pelbagai kegunaan. Terangkan keperluan umum yang digunapakai dalam GMS.

[10 marks]

[10 markah]

- CLO1 (c) Calculate the grade for wood measuring 8-inch width and 12 feet long with wood defects as shown in Figure B3(c). Refer to the attached Appendix A to determine the wood grade.

Kirakan gred untuk kayu berukuran 8 inci lebar dan 12 kaki panjang dengan kecacatan kayu seperti yang ditunjukkan dalam Rajah B3(c). Rujuk Lampiran A yang dilampirkan untuk menentukan gred kayu.

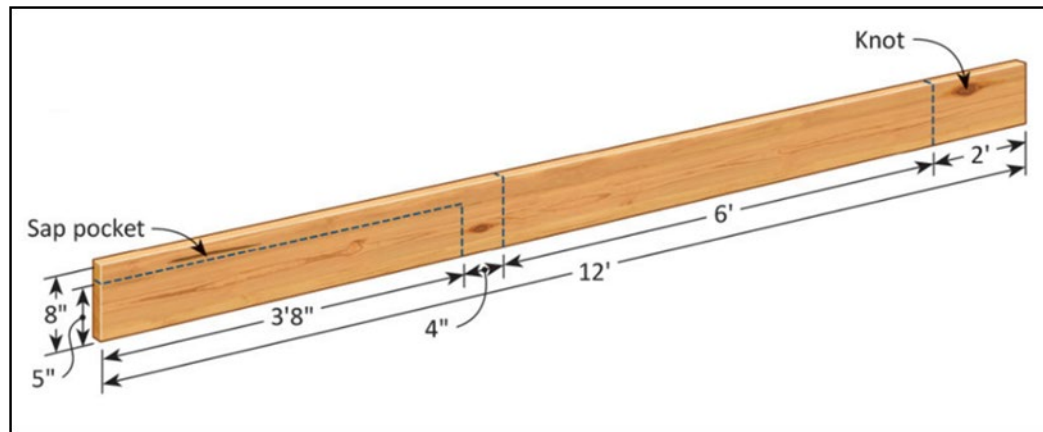

Figure B3(c) / Rajah B3(c)

[10 marks]

[10 markah]

QUESTION 4

SOALAN 4

- CLO1 (a) Give examples of imported timber products.

Berikan contoh produk kayu yang diimport.

[5 marks]

[5 markah]

- CLO1 (b) The COVID-19 pandemic and its economic implications have significantly influenced the tropical timber trade in all main trading locations, with potentially long-term effects. Explain current issues in the global timber trade based on this statement.

Pandemik COVID-19 dan implikasi ekonominya mempunyai pengaruh yang ketara ke atas perdagangan kayu tropika di semua lokasi perdagangan utama, dengan potensi kesan jangka panjang. Terangkan isu-isu semasa dalam perdagangan kayu global berdasarkan pernyataan ini.

[10 marks]

[10 markah]

- CLO1 (c) Malaysia, as a major producer and exporter of tropical timber products, has taken significant steps to ensure that it can provide timber products sourced from sustainably managed forests. Explain the Malaysian Timber Certification Scheme (MTCS) which is enforced to ensure the target is achieved.

Malaysia, sebagai pengeluar dan pengeksport utama produk kayu tropika, telah mengambil langkah penting untuk memastikan ia dapat menyediakan produk kayu yang diperolehi daripada hutan yang diuruskan secara mampan. Terangkan Skim Pensijilan Kayu Malaysia (MTCS) yang dikuatkuasakan bagi memastikan sasaran tercapai.

[10 marks]

[10 markah]

SOALAN TAMAT

Table 1: Grading requirement for GMS

GRADE	(I) PRIME	(II) SELECT	(III) STANDARD	(V) SERVICEABLE
h)	<p>Cutting Requirements</p> <p>*Surface area</p> <p>3 to < 5</p> <p>5 to < 8</p> <p>8 to < 11</p> <p>11 to < 14</p> <p>14 & up</p> <p>Percentage clear</p> <p>100% (12/12)</p> <p>91 2/3% (11/12)</p> <p>83 1/3% (10/12)</p> <p>or 91 2/3% (11/12)</p> <p>83 1/3% (10/12)</p> <p>or 91 2/3% (11/12)</p> <p>83 1/3% (10/12)</p> <p>or 91 2/3% (11/12)</p> <p>83 1/3% (10/12)</p> <p>or 91 2/3% (11/12)</p> <p>minimum size of cuttings:</p> <p>4" x 5" or 5" x 4"</p>	<p>*Surface area</p> <p>2.5 to < 3</p> <p>3 to < 5</p> <p>5 to < 8</p> <p>8 to < 11</p> <p>11 to < 14</p> <p>14 & up</p> <p>Percentage clear</p> <p>100% (12/12)</p> <p>75% (9/12)</p> <p>75% (9/12)</p> <p>75% (9/12)</p> <p>75% (9/12)</p> <p>75% (9/12)</p> <p>minimum size of cuttings:</p> <p>4" x 3" or 3" x 4"</p>	<p>*Surface area</p> <p>2.5 to < 5</p> <p>5 to < 8</p> <p>8 to < 11</p> <p>11 to < 14</p> <p>14 & up</p> <p>Percentage clear</p> <p>66 2/3% (8/12)</p> <p>66 2/3% (8/12)</p> <p>66 2/3% (8/12)</p> <p>66 2/3% (8/12)</p> <p>66 2/3% (8/12)</p> <p>(CFC includes bright sapwood)</p> <p>minimum size of cuttings:</p> <p>3" x 3" or 4" x 2"</p>	<p>*Surface area</p> <p>2.5 to < 5</p> <p>5 to < 8</p> <p>8 to < 11</p> <p>11 to < 14</p> <p>14 & up</p> <p>Percentage clear</p> <p>66 2/3% (8/12)</p> <p>66 2/3% (8/12)</p> <p>66 2/3% (8/12)</p> <p>66 2/3% (8/12)</p> <p>66 2/3% (8/12)</p> <p>(SFC admits brittle heart)</p> <p>minimum size of cuttings:</p> <p>3" x 3" or 4" x 2"</p>
i)	<p>Grading Requirements</p> <p>Admits pieces that yield the required percent of CFCs, the portion outside will admit splits as in item 4.6 page 16, and SFC defects</p>	<p>Admits pieces that yield the required percent of CFCs, the portion outside will admit splits as in item 4.6 page 16, and SFC defects</p>	<p>Admits pieces that yield the required percent of CFCs, the portion outside will admit splits as in item 4.6 page 16, SFC defects and SDs not materially affecting the strength of the piece</p>	<p>Admits piece that yields the required percent of SFCs, the portion outside will admit splits as in item 4.6 page 16, wane, brittle heart as in Table above and any SDs not materially affecting the strength of the piece</p>
IV.	<p>SOUND (or BHD - Borer Holes No Defect) - As for Prime, Select, and Standard grades except that pin and unstained shot holes are admitted in the cuttings, as defined in Rule 24, item 24.3.</p>			
VI.	<p>UTILITY - As for Serviceable grade except that wane is not to exceed one quarter the width of the piece; cuttings will admit any sound defects not materially affecting the strength of the piece.</p>			
*	<p><i>Surface area of piece in square feet</i></p>			

(Source: The Malaysian Grading Rules for Sawn Hardwood Timber 2009 Edition, MTIB)