

SULIT



BAHAGIAN PEPERIKSAAN DAN PENILAIAN
JABATAN PENDIDIKAN POLITEKNIK
KEMENTERIAN PENDIDIKAN TINGGI

JABATAN KEJURUTERAAN ELEKTRIK

PEPERIKSAAN AKHIR

SESI JUN 2015

DEJ3133: BASIC CONTROL SYSTEM

TARIKH : 05 NOVEMBER 2015

MASA : 8.30 AM – 10.30 AM (2 JAM)

Kertas ini mengandungi **TIGA BELAS (13)** halaman bercetak.

Bahagian A: Objektif (10 soalan)

Bahagian B: Struktur (4 soalan)

Bahagian C: Esei (2 soalan)

Dokumen sokongan yang disertakan :

Jadual Laplace, Jadual Pengurangan Gambarajah Blok

JANGAN BUKA KERTAS SOALAN INI SEHINGGA DIARAHKAN

(CLO yang tertera hanya sebagai rujukan)

SULIT

SECTION A : 10 MARKS
BAHAGIAN A : 10 MARKAH

INSTRUCTION:

This section consists of **TEN (10)** objective questions. Mark your answers in the OMR form provided.

ARAHAN :

*Bahagian ini mengandungi **SEPULUH (10)** soalan objektif. Tandakan jawapan anda di dalam borang OMR yang disediakan.*

CLO1
C1

1. State the portion of a system to be controlled or regulated.

Nyatakan bahagian sistem yang akan dikawal atau diatur.

- | | |
|--------------------------------------|------------------------------------|
| A. Disturbance.
<i>Gangguan.</i> | C. Controller.
<i>Pengawal.</i> |
| B. Comparator.
<i>Pembanding.</i> | D. Process.
<i>Proses.</i> |

CLO1
C2

2. A combination or an arrangement of different physical components which act together to achieve certain objective. This statement refer to _____.

Gabungan atau susunan komponen fizikal yang berbeza yang bertindak bersama untuk mencapai objektif tertentu. Kenyataan ini merujuk kepada _____.

- | | |
|--|---|
| A. System.
<i>System.</i> | C. Physical system.
<i>Sistem fizikal.</i> |
| B. Control system.
<i>Sistem kawalan.</i> | D. Controller.
<i>Pengawal.</i> |

CLO1
C2

3. Closed loop control systems should be described as the following properties

EXCEPT:

*Sistem kawalan gelung tertutup mempunyai ciri-ciri berikut **KECUALI** :*

- | |
|---|
| A. Bandwidth is large.
<i>Lebar jalur yang besar.</i> |
| B. There is a reduced effect of nonlinearities and distortions.
<i>Kesan ketidaklinearan dan gangguan dikurangkan.</i> |
| C. A system in which the controlling action is dependent on the changes of output.
<i>Tindakan kawalan sistem adalah bergantung kepada perubahan keluaran.</i> |
| D. Accuracy of this system depends on calibration.
<i>Ketepatan sistem bergantung kepada penentu ukuran</i> |

CLO1
C2

9. Choose the suitable control system based on the statement below:

Pilih sistem kawalan yang bersesuaian dengan pernyataan berikut:

- A system in which the primary variable is controlled by adjusting the set point of a related secondary variable controller.
- Sistem di mana pembolehubah utama dikawal dengan melaraskan titik set pengawal yang berkaitan dengan pembolehubah sekunder.

- A. Ratio control system.
sistem kawalan nisbah.
- B. Open loop control system.
sistem kawalan gelung buka.
- C. Proportional control system.
sistem kawalan berkadaran.
- D. Multiple loop control system.
sistem kawalan gelung berbilang.

CLO2
C3

10. Consider the following statements:

Pertimbangkan kenyataan berikut:

- i. When the error is zero or constant, the controller output is zero.
Apabila ralat adalah sifar atau malar, keluaran pengawal adalah sifar.
- ii. It is never used on its own.
Ia tidak pernah digunakan secara bersendirian.
- iii. Instability of system.
Ketidakstabilan sistem.

Generalize the **CORRECT** statements for derivative controller.*Pilih pernyataan umum yang BETUL tentang pengawal pembezaan.*

- | | | | |
|---|---------------------------------|---|---|
| A | i and ii.
<i>i dan ii.</i> | C | ii and iii.
<i>ii dan iii.</i> |
| B | i and iii.
<i>i dan iii.</i> | D | i, ii and iii.
<i>i, ii dan iii.</i> |

SECTION B : 60 MARKS

BAHAGIAN B : 60 MARKAH

INSTRUCTION:

This section consists of **FOUR (4)** structured questions. Answer **ALL** questions.

ARAHAN:

*Bahagian ini mengandungi EMPAT (4) soalan berstruktur. Jawab SEMUA soalan.*CLO1
C1

QUESTION 1(a)

State **THREE (3)** real time applications of closed loop system.

SOALAN 1(a)

Nyatakan TIGA (3) aplikasi masa sebenar bagi sistem gelung tertutup.

[3 marks]

[3 markah]

CLO1
C2

QUESTION 1(b)

Differentiate between open and closed loop control system.

SOALAN 1(b)

Bezakan di antara sistem kawalan suapbalik dan suap hadapan

[5 marks]

[5 markah]

CLO2
C3

QUESTION 1(c)

Sketch the general closed loop control system diagram with complete labels for each element.

SOALAN 1(c)

Lakarkan dan labelkan dengan lengkap bagi diagram sistem kawalan gelung tertutup.

[7 marks]

[7 markah]

CLO1
C1

QUESTION 2(a)

List **THREE (3)** disadvantages of Transfer Function.

SOALAN 2(a)

Senaraikan **TIGA (3)** keburukan Rangkap Pindah.

[3 marks]
[3 markah]

CLO1
C2

QUESTION 2(b)

Referring to the block diagram in Figure B2(b), determine the transfer function of the system.

SOALAN 2(b)

Merujuk kepada Rajah B2(b), tentukan rangkap pindah untuk sistem ini.

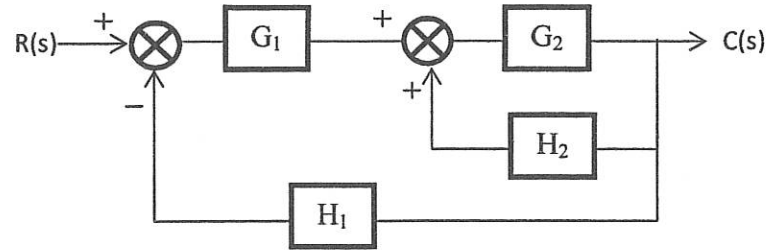

Figure B2(b) / Rajah B2(b)

[5 marks]
[5 markah]

CLO2
C3

QUESTION 2(c)

Based on the signal flow graph shown in Figure B2(c), calculate the value of $\frac{C(s)}{R(s)}$ ratio.

SOALAN 2(c)

Berdasarkan Graf Signal Isyarat yang ditunjukkan dalam Rajah B2(c), kirakan nilai

nisbah $\frac{C(s)}{R(s)}$

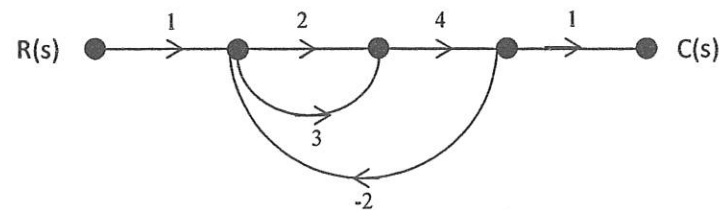

Figure B2(c) / Rajah B2(c)

[7 marks]
[7 markah]

CLO1
C1

QUESTION 3(a)

Define the following terms:

- i. Time Response.
- ii. Steady State Error.

[1.5 marks]
[1.5 markah]

SOALAN 3(a)

Takrifkan istilah berikut:

- i. Masa Sambutan.
- ii. Ralat Keadaan Mantap.

[1.5 marks]
[1.5 markah]

CLO1
C2

QUESTION 3(b)

Explain maximum overshoot of transient response and sketch a suitable graph.

SOALAN 3(b)

Jelaskanlanjakan maksimum sambutan fana dan lakarkan graf yang sesuai.

[5 marks]
[5 markah]

CLO2
C3

QUESTION 3(c)

Refer to Figure B3(c), calculate the value of K so that the damping ratio ζ is 0.4

SOALAN 3(c)

Rujuk Rajah B3(c), kirakan nilai K supaya nisbah redaman, ζ ialah 0.4

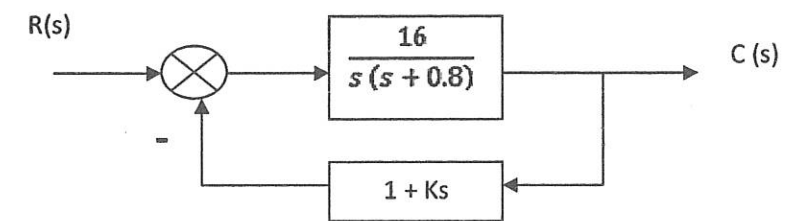

Figure B3(c) / Rajah B3(c)

[7 marks]
[7 markah]

CLO1
C1**QUESTION 4(a)**

The controllers are basically classified as discontinuous and continuous controller. State the differences of these two controller.

SOALAN 4(a)

Pengawal pada dasarnya dikelaskan kepada pengawal tidak berterusan dan berterusan.

Nyatakan perbezaan kedua-dua pengawal tersebut.

[3 marks]

[3 markah]

CLO1
C2**QUESTION 4(b)**

Describe **FOUR (4)** characteristics of Proportional (P) control mode.

SOALAN 4(b)

Terangkan **EMPAT (4)** ciri mod kawalan Kadaran (P).

[5 marks]

[5 markah]

CLO2
C3**QUESTION 4(c)**

A Proportional + Integral (P+I) controller is used to control certain processes. The settings of the controller are $k_p = 2\%$ and $k_i = 4\%$ per min. while $p(0) = 50\%$, the error signal is found to be $(3t + 7)$ where t is the time. Calculate the controller output percentage (%) after 1.5 minutes.

SOALAN 4(c)

Satu pengawal kadaran + kamiran (P+I) digunakan untuk mengawal proses tertentu.

Tetapan pengawal $k_p = 2\%$ dan $k_i = 4\%$ setiap min. manakala $p(0) = 50\%$, isyarat ralat ialah $(3t + 7)$ di mana t ialah masa. Kirakan peratusan (%) keluaran pengawal selepas 1.5 minit.

[7 marks]

[7 markah]

SECTION C : 30 MARKS**BAHAGIAN C : 30 MARKAH****INSTRUCTION:**

This section consists of **TWO (2)** essay questions. Answer **ALL** questions.

ARAHAN:

Bahagian ini mengandungi **DUA (2)** soalan esei. Jawab **SEMUA** soalan.

QUESTION 1**SOALAN 1**CLO2
C3

Generalize the transfer function of the system shown in Figure C1 by using Block Reduction Method.

Permudahkan rangkap pindah bagi sistem yang ditunjukkan di Rajah C1 dengan menggunakan Kaedah Pengecilan Blok Diagram.

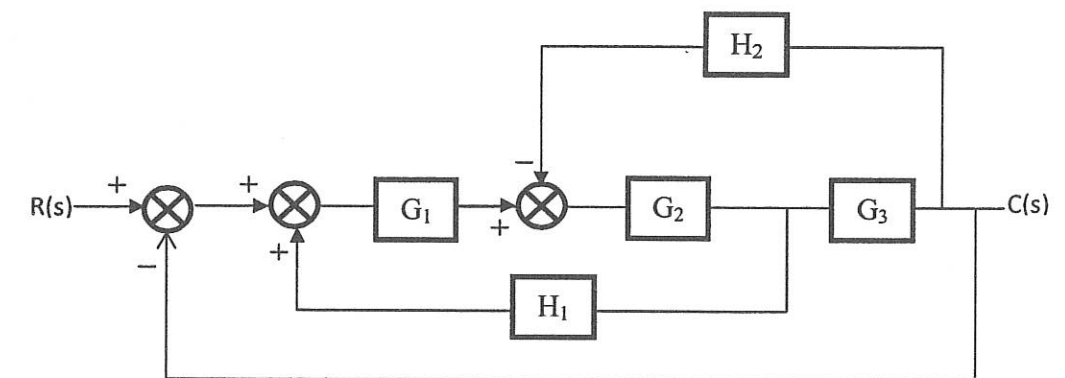

Figure C1 / Rajah C1

[15 marks]

[15 markah]

QUESTION 2
SOALAN 2

CLO2
C3

Consider the closed loop system given is,

Pertimbangkan sistem gelung tertutup yang diberikan oleh,

$$\frac{C(s)}{R(s)} = \frac{\omega_n^2}{s^2 + 2\zeta\omega_n s + \omega_n^2}$$

Calculate the values of damping ratio, ζ and damped natural frequency, ω_n so that the system response to a step input with approximately 5% overshoot and with a settling time of 2 seconds.

Kirakan nilai nisbah redaman dan frekuensi tabii redaman bagi sambutan sistem terhadap unit langkah dengan nilai terlajak dengan anggaran sebanyak 5% dan masa penganapan 2 saat.

[15 marks]
[15 markah]

SOALAN TAMAT

STANDARD LAPLACE TRANSFORM PAIRS

$f(t) = \mathcal{L}^{-1}\{F(s)\}(t)$	$F(s) = \mathcal{L}\{f(t)\}(s) = \int_0^{\infty} e^{-st} f(t) dt$
1	$\frac{1}{s}, \quad s > 0$
$t^n, \quad n \text{ an integer}$	$\frac{n!}{s^{n+1}}, \quad s > 0$
e^{at}	$\frac{1}{s-a}, \quad s > a$
$\sin bt$	$\frac{b}{s^2 + b^2}, \quad s > 0$
$\cos bt$	$\frac{s}{s^2 + b^2}, \quad s > 0$
$e^{at} f(t)$	$F(s-a)$
$e^{at} t^n, \quad n \text{ an integer}$	$\frac{n!}{(s-a)^{n+1}}, \quad s > a$
$e^{at} \sin bt$	$\frac{b}{(s-a)^2 + b^2}, \quad s > a$
$e^{at} \cos bt$	$\frac{(s-a)}{(s-a)^2 + b^2}, \quad s > a$
$t \sin bt$	$\frac{2bs}{(s^2 + b^2)^2}, \quad s > 0$
$t \cos bt$	$\frac{s^2 - b^2}{(s^2 + b^2)^2}, \quad s > 0$
$u_c(t)f(t), \quad c \geq 0$ $u_c(t)f(t-c), \quad c \geq 0^{**}$	$e^{-cs}\mathcal{L}\{f(t+c)\}(s)$ $e^{-cs}\mathcal{L}\{f(t)\}(s)$
$y' = \dot{y} = \frac{dy}{dt}$	$sY(s) - y(0)$
$y'' = \ddot{y} = \frac{d^2y}{dt^2}$	$s^2Y(s) - sy(0) - \dot{y}(0)$

BLOCK DIAGRAM REDUCTION RULES

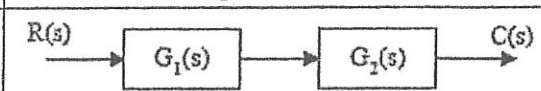
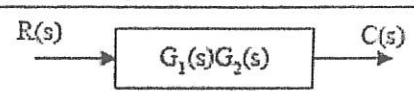
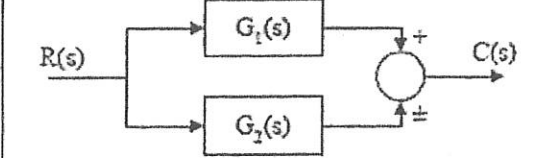
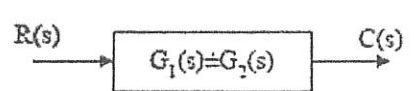
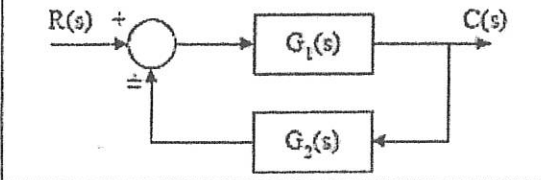
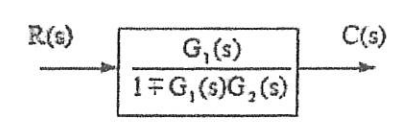
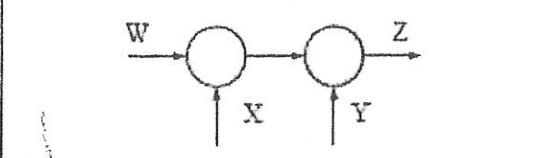
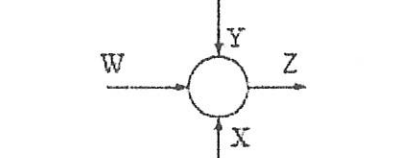
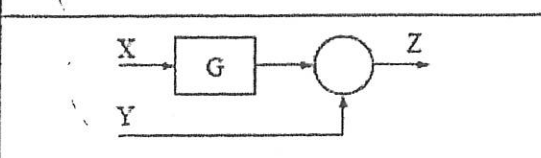
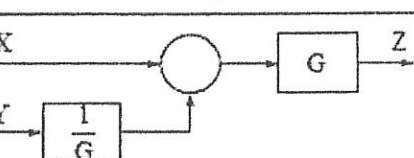
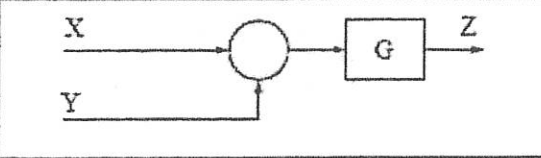
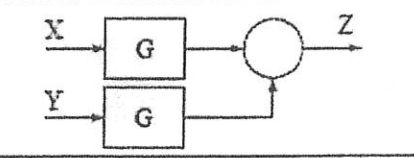
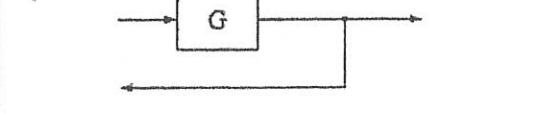
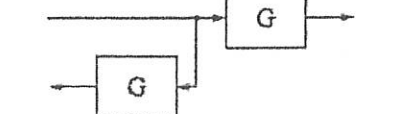
Case	Original Structure	Equivalent Structure
1		
2		
3		
4		
5		
6		
7		
8	