



PNEUMATICS CIRCUIT DESIGN

DR. MOHD ELIAS DAUD
NAZRATULHUDA BINTI AWANG@HASHIM

MECHANICAL ENGINEERING DEPARTMENT

A close-up, artistic photograph of brass gears and mechanical components, likely from a watch movement. The gears are highly detailed with fine teeth and are set against a blurred background of other mechanical parts. The lighting is soft, highlighting the metallic texture and the intricate design of the machinery.

PNEUMATICS CIRCUIT DESIGN

First Edition

ALL RIGHTS RESERVED.

No part of this publication may be reproduced, distributed or transmitted in any form or by any means, including photocopying, recording or other electronic or mechanical methods, without the prior written permission of Politeknik Sultan Salahuddin Abdul Aziz Shah.

PNEUMATICS CIRCUIT DESIGN

Dr. Mohd Elias Daud
Nazratulhuda Binti Awang@Hashim

ISBN No: e ISBN 978-967-2044-85-7

First Published in 2021 by:

UNIT PENERBITAN

Politeknik Sultan Salahuddin Abdul Aziz Shah
Persiaran Usahawan,
Seksyen U1,
40150 Shah Alam
Selangor

Telephone No. : 03 5163 4000

Fax No. : 03 5569 1903

PREFACE

Pneumatics technology is one of the important part in automation system. It can be divided into two; fully pneumatic and electro-pneumatic control. The learning system is therefore broken down in this chapter focuses only fully pneumatic system as follows:

- The components of the pneumatic
- Basic control in pneumatic system
- Single cylinder control
- Multiple cylinder control
- Pneumatic accessories

The learning system for pneumatic technology is continuously updated and expanded in accordance with developments in the field of education, as well as actual professional practice. This training packages deal with various component of pneumatic and very helpful for engineering technician for maintenance of the machine part.

1.0 Pneumatics Circuit Design

1.1 Movement for One Cylinder

1.1.1 Pneumatic circuit diagram for one cylinder based on:

- a. Direct control
- b. Indirect control

1.1.2 Pneumatic circuit diagram:

- a. Dual pressure valve (AND Function)
- b. Shuttle valve (OR Function)
- c. 5/2-way double pilot valve
- d. Pressure sequence valve
- e. Time delay valve

1.1.3 Design the pneumatic circuit diagram based on task given.

1.2 Development of Multiple Cylinder Circuits

1.2.1 Sequence control for numerous cylinder

- a. Coordinated motion
- b. Displacement step diagram

1.2.2 Circuit solution for overlapping signals

- a. Roller lever valve with Idle return solution
- b. Reversing valve solution (Cascade)

1.0 Introduction

The Pneumatic system supported with several components, which is consist of Air generation unit, Input unit, Control unit, Processing unit and Actuating Unit (Figure 1). In this section all pneumatic component will be discussed.

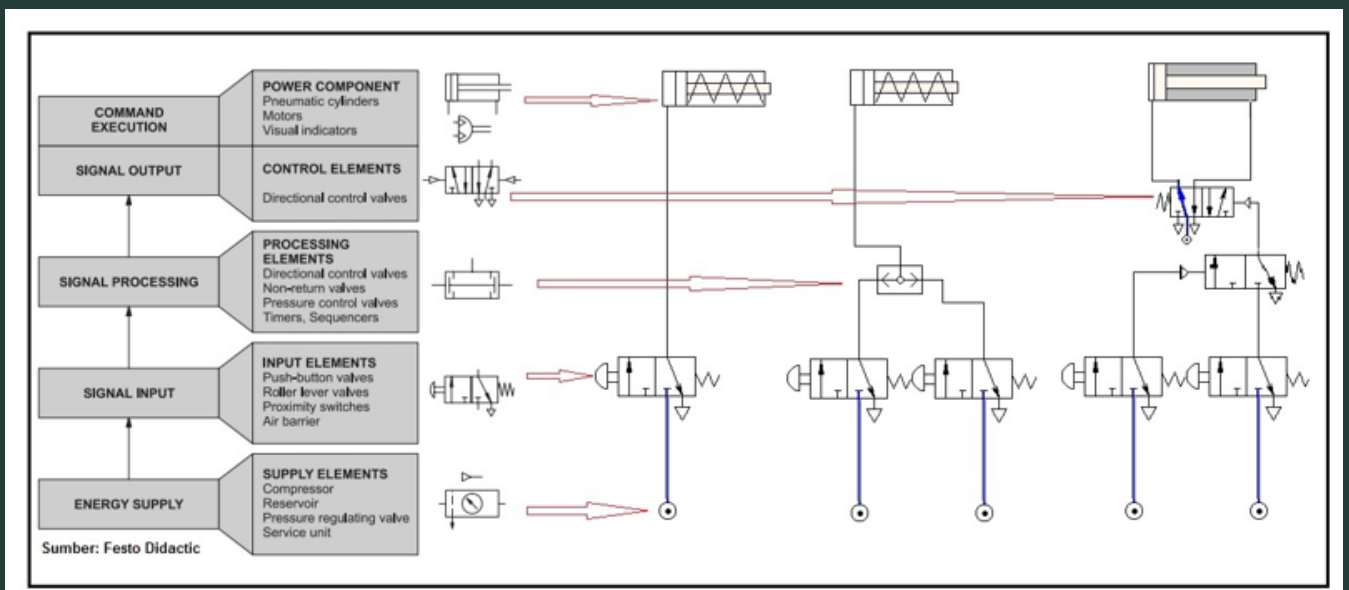

Figure 1: Pneumatic Circuit Flow

1.1 Directional Control valve Symbols

- Directional control valve is represented by the number of controlled connections, the number of positions and the flow path.
- Numbering system is used to designate directional control valves and is in accordance with DIN ISO 5599-3 (Figure 2).
- Working lines :



| ISO 5599-3 | Lettering System | Port or Connection |
|------------|------------------|--------------------|
| 1 | P | Pressure port |
| 2, 4 | A, B | Working lines |
| 3, 5 | R, S | Exhaust ports |

Figure 2: Directional Control Valve (DCV) Port

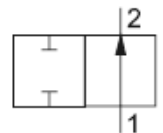

 Number of ports
 Number of positions
2/2 – Way directional control valve, normally open

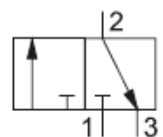

3/2 – Way directional control valve, normally closed

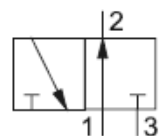

3/2 – Way directional control valve, normally open



4/2 – Way directional control valve
 Flow from 1 → 2 and from 4 → 3

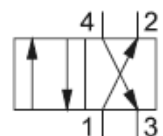

5/2 – Way directional control valve
 Flow from 1 → 2 and von 4 → 5

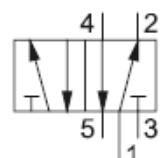

5/3 – Way directional control valve
 Mid position closed

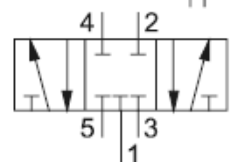

Figure 3: The Type of DCV

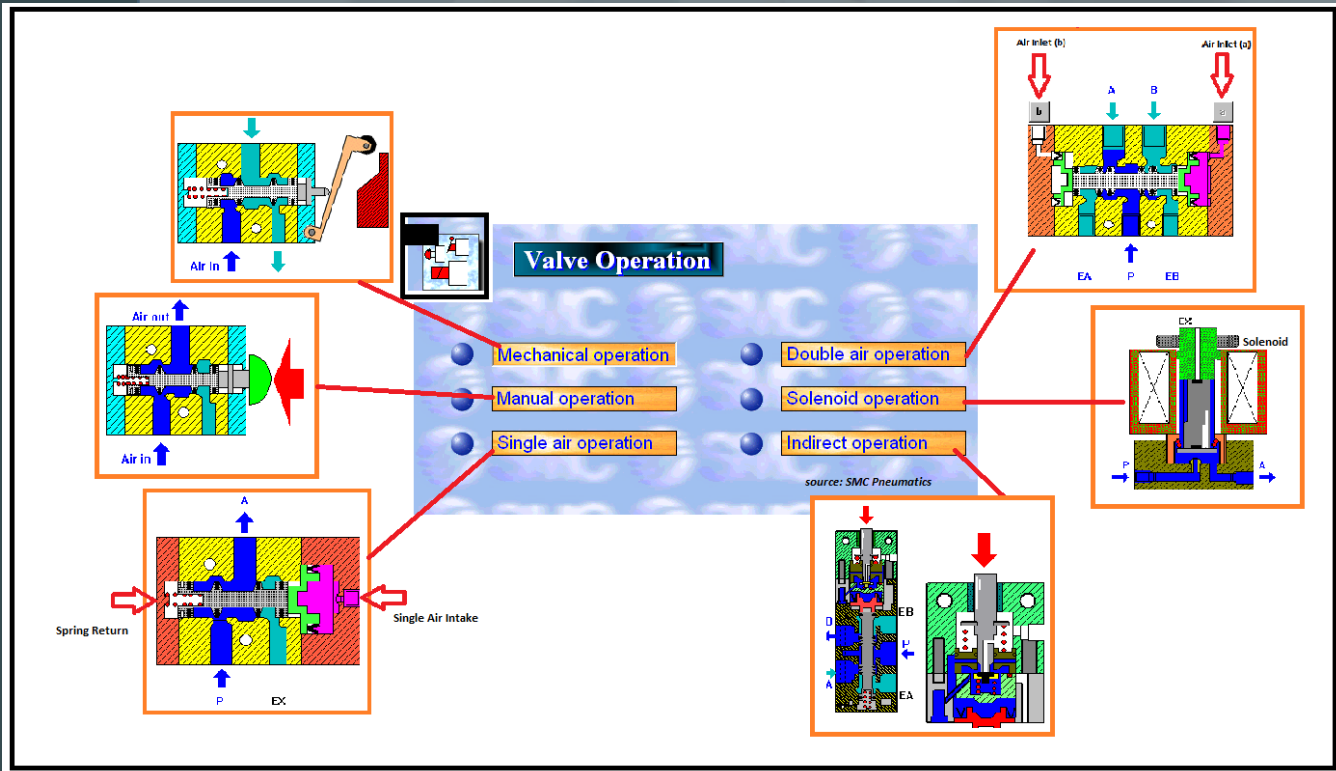

Figure 4: Valve Operation Method

1.2 Pneumatic Cylinder

Pneumatic cylinders can be controlled by the following methods:

- A. Direct control of Single and Double acting cylinder
- B. Indirect Control of Cylinder with Single Piloted Final Control Valve
- C. Indirect Control of Cylinder with Double Piloted Final Control Valve
- D. In the indirect control actuation, a pilot signal from a 3/2 N.C. valve is used to
- E. activate pilot ports of final control valve.



A. Direct control of Single and Double Acting Cylinder

1. Direct control of Single Acting Cylinder

- Direct control of single acting cylinder consist of single acting cylinder and 3/2 DCV valve push button with spring return (Figure 5).
- By pressing a Push Button, cylinder move forward, by releasing a Push Button, the cylinder back to its retract position.

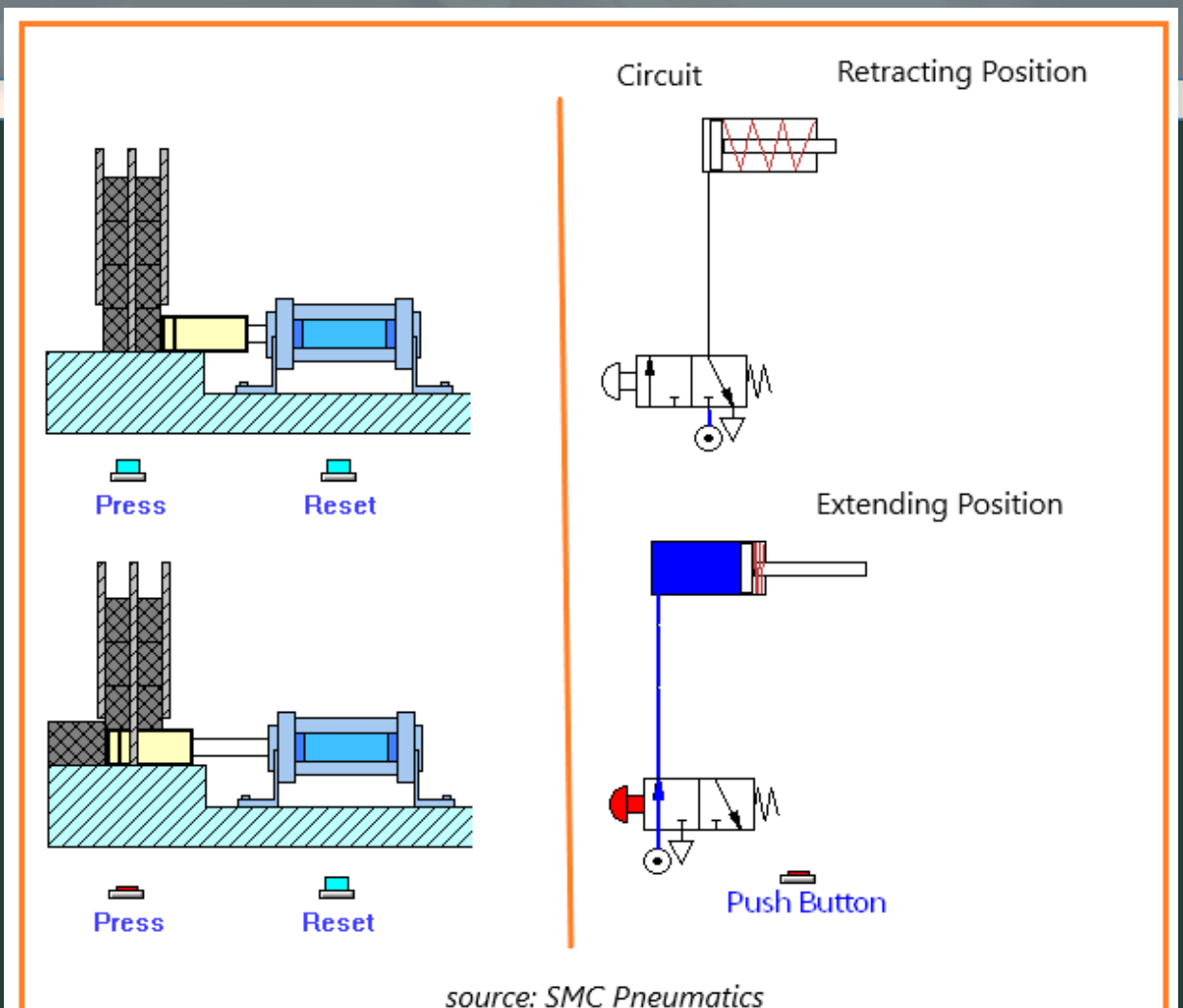

Figure 5: Direct Control of Single Acting Cylinder

2. Direct control of Double Acting Cylinder

- Figure 6 shows a double acting cylinder controlled by pressing a push button.
- Direct control of double acting cylinder consist of double acting cylinder and 5/2 DCV valve push button with spring return.
- By pressing a Push Button, cylinder move forward, by releasing a Push Button, the cylinder back to its retract position.

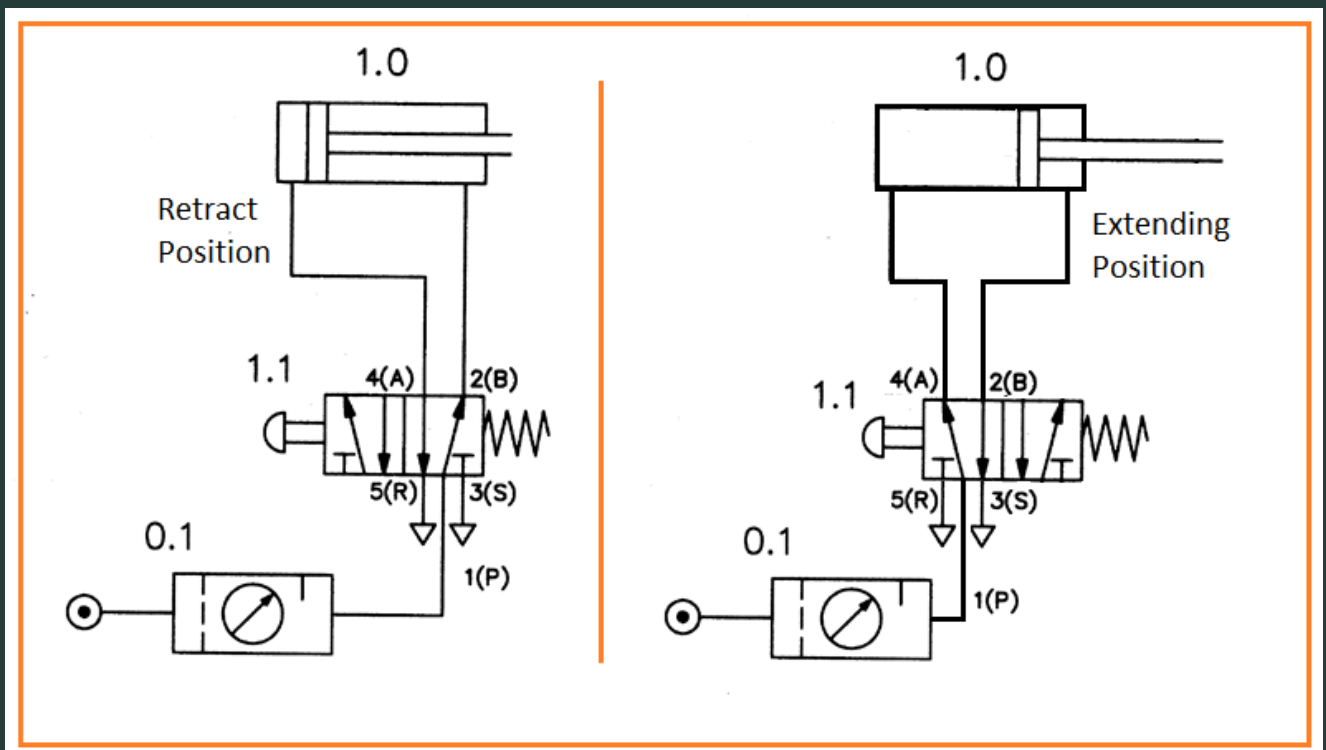

Figure 6: Direct Control of Double Acting Cylinder

B. Indirect control of Single and Double Acting Cylinder

1. Indirect control of Single Acting Cylinder

- Indirect control of single acting cylinder consist of single acting cylinder and 3/2 DCV valve push button with spring return and Final control valve (3/2 DCV, air operated)(Figure 7).
- By pressing a Push Button, cylinder move forward, by releasing a Push Button, the cylinder back to its retract position.

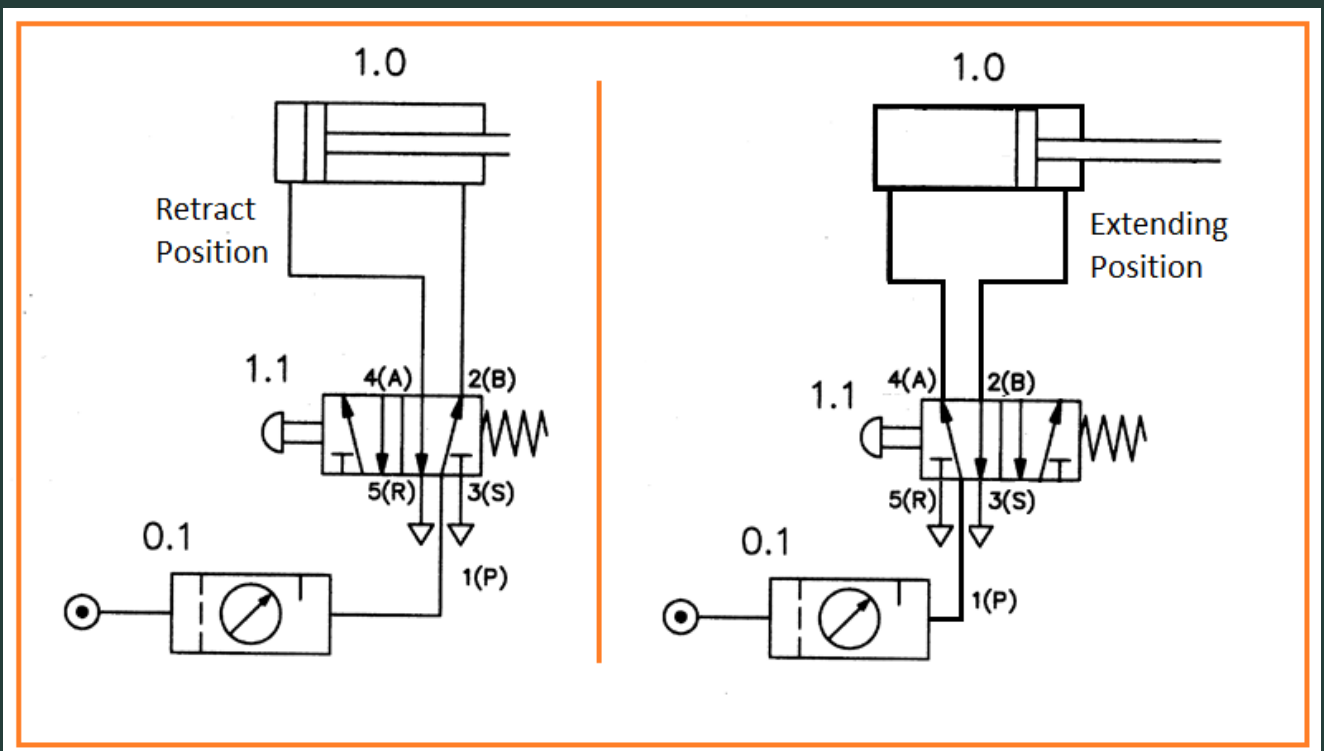

Figure 6: Direct Control of Double Acting Cylinder

2. Indirect control of Double Acting Cylinder

- Indirect control of single acting cylinder consist of single acting cylinder and 3/2 DCV valve push button with spring return and Final control valve (5/2 DCV, air operated)(Figure 8)
- By pressing a Push Button, cylinder move forward, by releasing a Push Button, the cylinder back to its retract position.

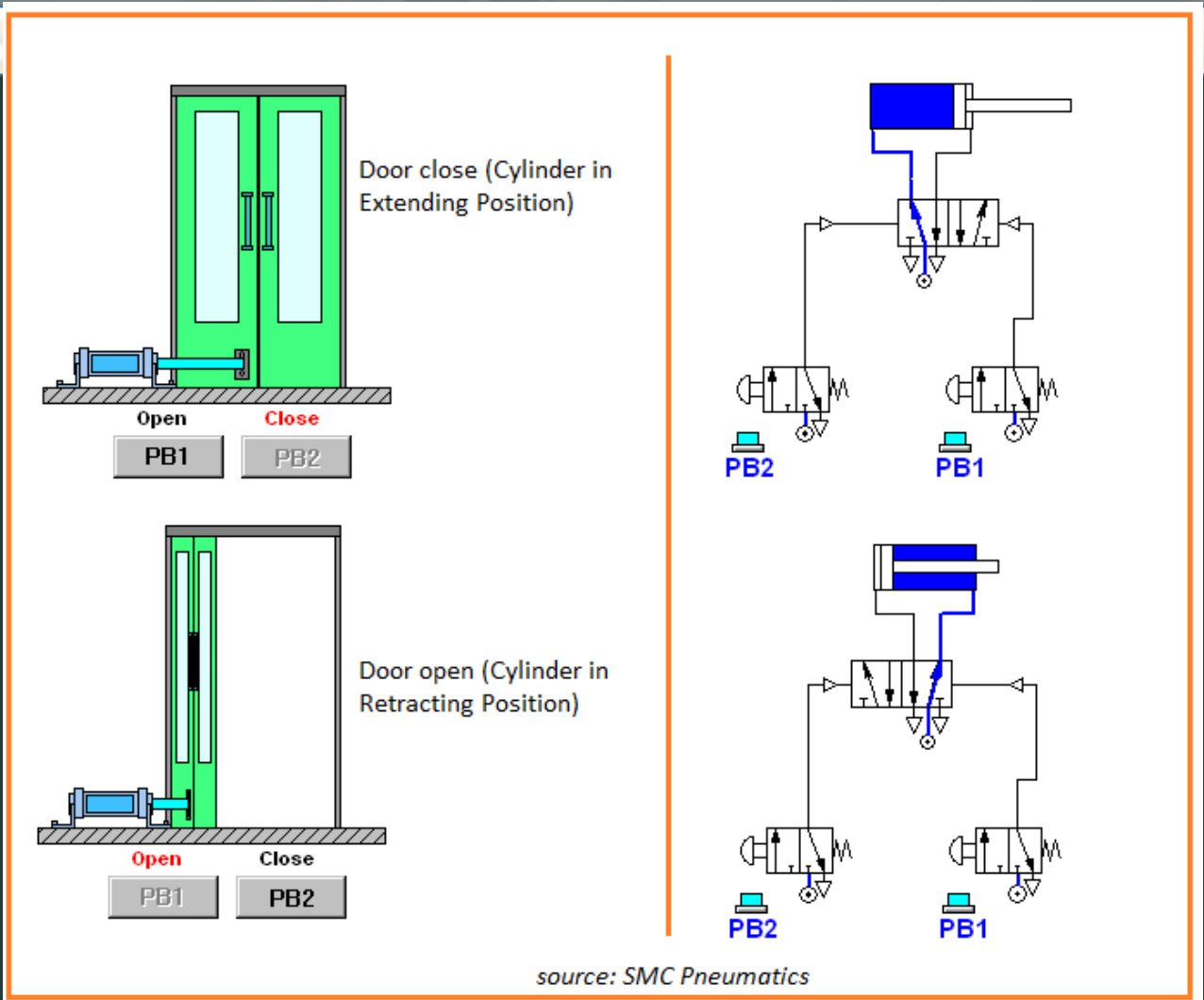
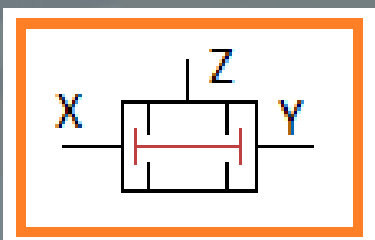

Figure 8: Indirect Control of Double Acting Cylinder

1.2.1 Pneumatic circuit diagram

a. Dual pressure valve (AND Function)

- Used for safety function; normally used in Pressed machine.
- Needs a two switches
- The dual-pressure valve is switched through to the output by applying compressed air to both of the inputs (AND function). (Festo)



AND Truth Table

| X | Y | Z |
|---|---|---|
| 0 | 0 | 0 |
| 0 | 1 | 0 |
| 1 | 0 | 0 |
| 1 | 1 | 1 |

| input | | Output | |
|-------|------------|--------|-----|
| 0 | Deactivate | 0 | Off |
| 1 | activate | 1 | On |

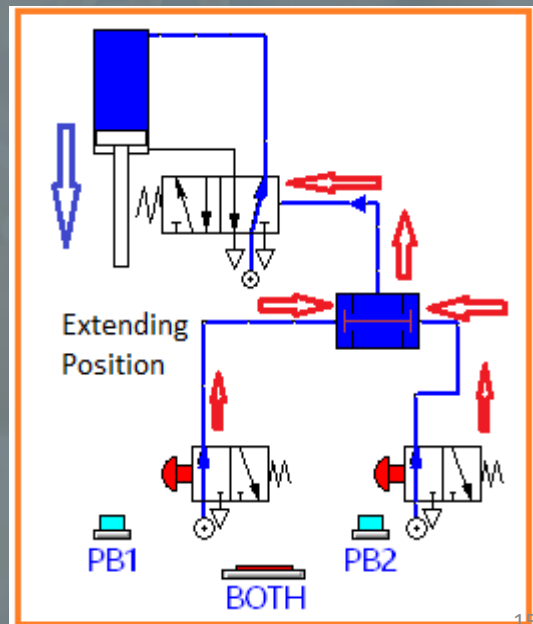
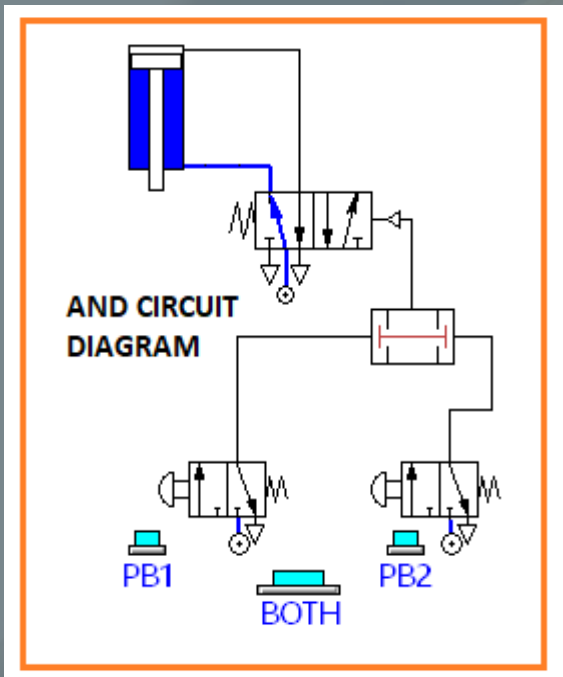

Figure 9: AND valve Function

1.2.1 Pneumatic circuit diagram

b. Shuttle valve (OR Function)

- Used for parallel application
- A shuttle valve, it allows pressure in a line to be obtained from alternative sources. It consists of a ball inside a cylinder, as shown in Figure 10.
- If pressure is applied to port X, the ball is blown to the right, blocking port Y and linking ports X and Z. Similarly, pressure to port Y alone connects ports Y and A and blocks port X.
- The Shuttle valve is switched through to the output by applying compressed air to either one of the inputs (OR).



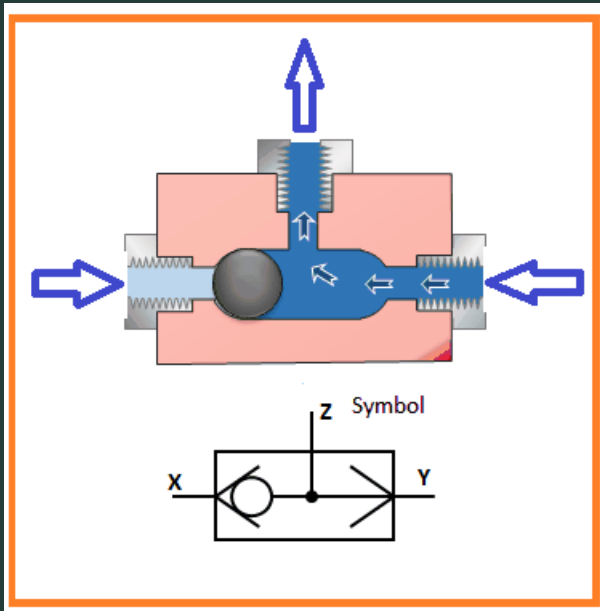

OR Truth Table

| X | Y | Z |
|---|---|---|
| 0 | 0 | 0 |
| 0 | 1 | 1 |
| 1 | 0 | 1 |
| 1 | 1 | 1 |

| input | | Output | |
|-------|------------|--------|-----|
| 0 | Deactivate | 0 | Off |
| 1 | activate | 1 | On |

Figure 10: OR Valve

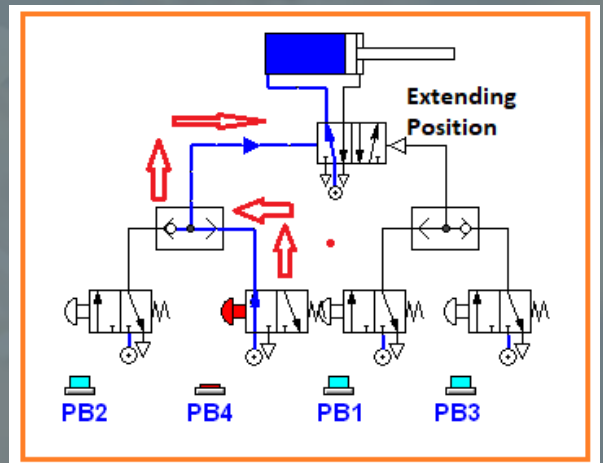
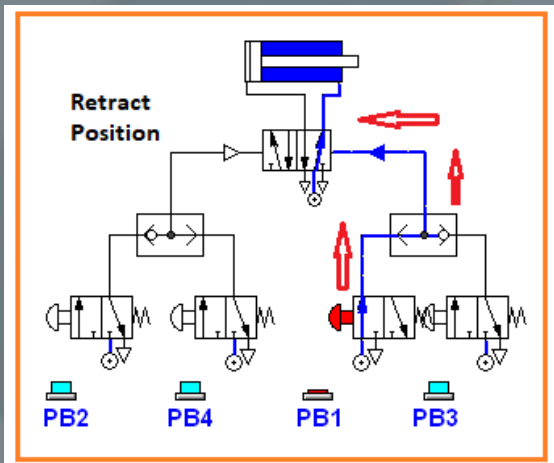

Figure 11: OR Function Circuit

1.2.1 Pneumatic circuit diagram

c. 5/2-way double pilot valve

- Valve 1V1 has double pilot, which, signal of 14 and 12 .
- For Extending action, signal 14, switch 1S1 supplied to the valve
- For Retracting action, signal 12, switch 1S2 supplied to the valve

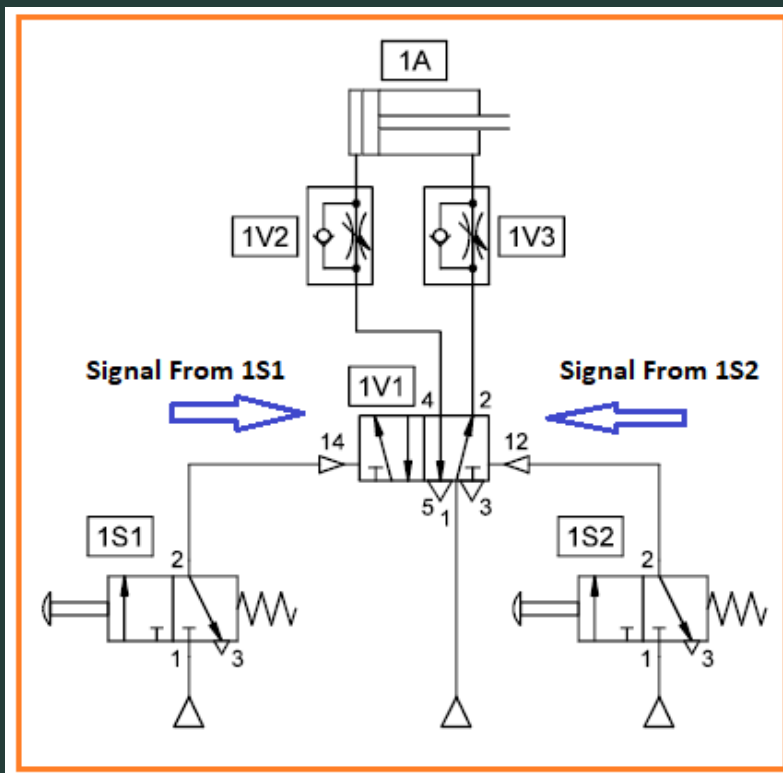
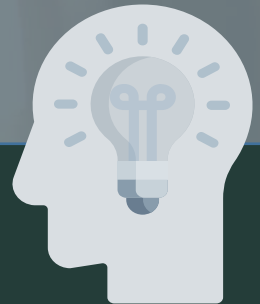

Figure 12: Double Air Operated Valve

d. Pressure sequence valve

- The sequence valve is a close relative of the pressure-relief valve and is used where a set of operations are to be controlled in a pressure-related sequence. A Figure 13 shows a typical example where a workpiece is pushed into position by cylinder B and clamped by cylinder A.
- Sequence valve V2 is connected to the extend line of cylinder B. When this cylinder is moving the workpiece, the line pressure is low, but rises once the workpiece hits the end stop. The sequence valve opens once its inlet pressure rises above a preset level.

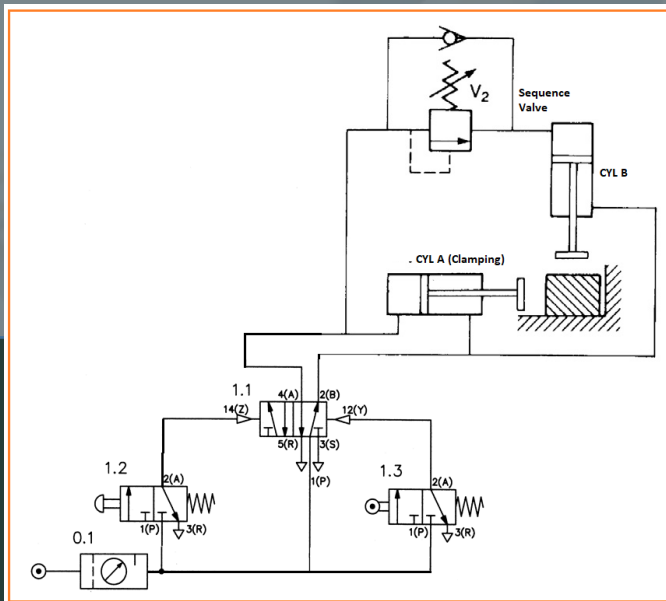

Figure 13: Sequence Valve

- Cylinder A then operates to clamp the workpiece. DCV valve (1.3) allows both cylinders to retract together through signal 12 of 5/2 DCV.
- The construction of a sequence valve. In many respects it is a variation on a relief valve, the main difference being leakage in a sequence valve drains to tank rather than to the outlet port.
- The valve is a two-way valve which is held closed by an adjustable pressure-setting spring. When the set pressure is reached the force from the pressure acting on the left-hand side of the spool overcomes the force of the spring and the spool moves to the right. Fluid now flows to the secondary circuit. Hydraulic sequence valves should not be confused with the pneumatic modular sequence valve of Figure 8.22.

1.2.1 Pneumatic circuit diagram

e. Time Delay Valve

- Used to delay a pneumatic signal
- Used to control the pilot operated valve.
- Figure 14 shows how the air controlled through combination valve (1V2). After a few second the pressure achieve a required pressure, in order to activate 3/2 valve, then the signal goes to 12 through 5/2 valve (1v3). The Cylinder 1A will retract.

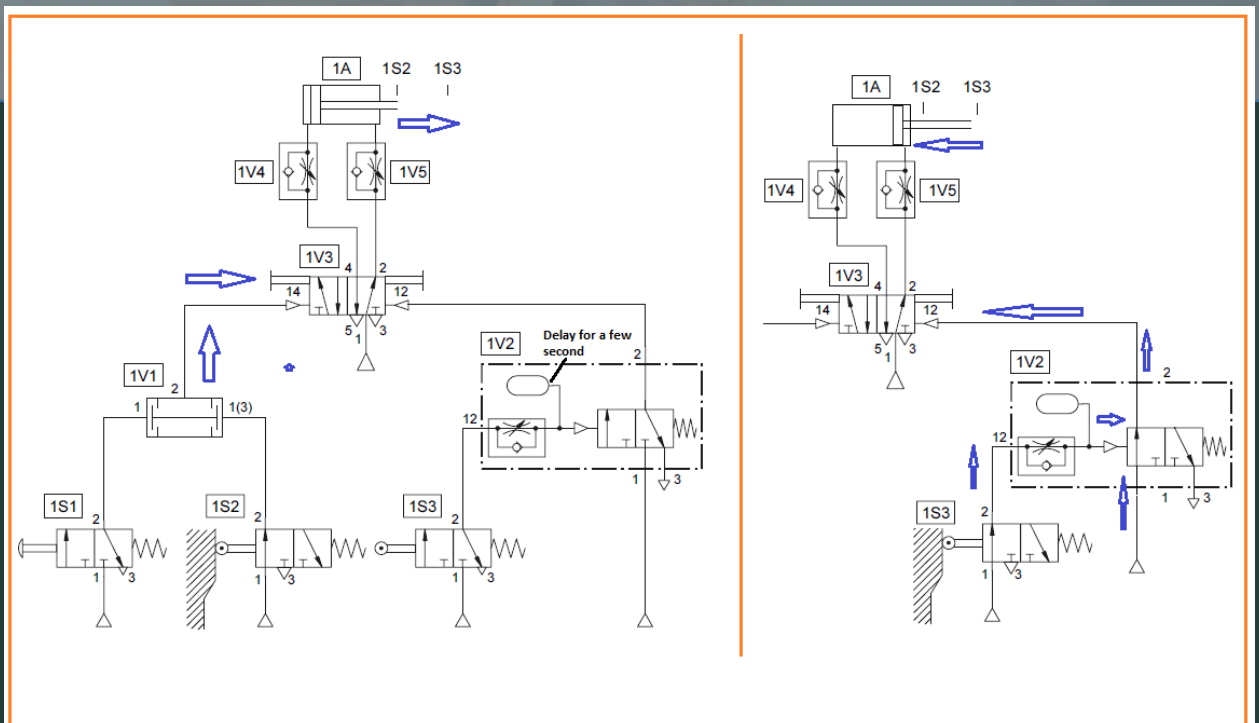

Figure 14: Time Delay Valve

Question: Design the pneumatic circuit diagram based on task given.

A double-acting cylinder is used to clamp components on a drill machine. Upon operation of a push button and its in start position, the clamping cylinder extends. Once the fully advanced position is reached and finish button is pressed, the cylinder is then immediately retract to the initial position. The cylinder retraction is to be adjustable. A new start cycle is only possible after the cylinder has fully retracted.

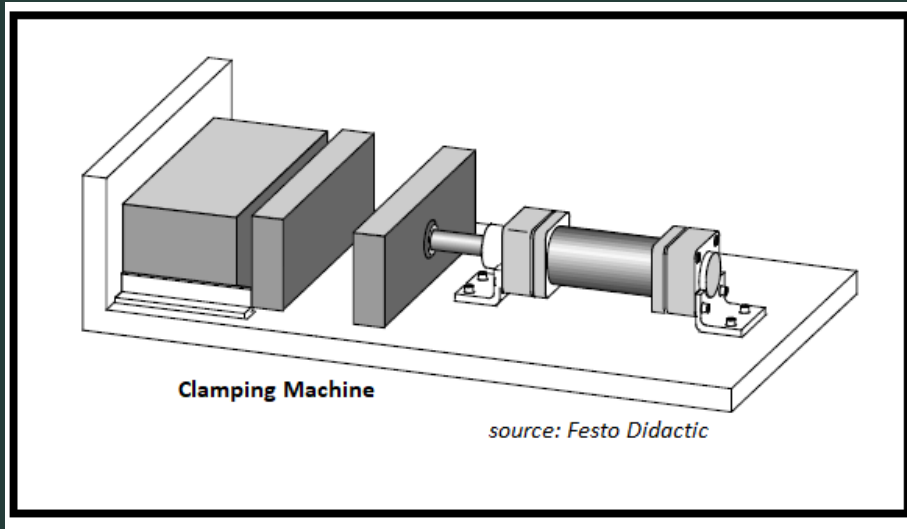

Figure 15: The Application of Time Delay Valve

Answer: The Solution of Double Acting Cylinder Circuit

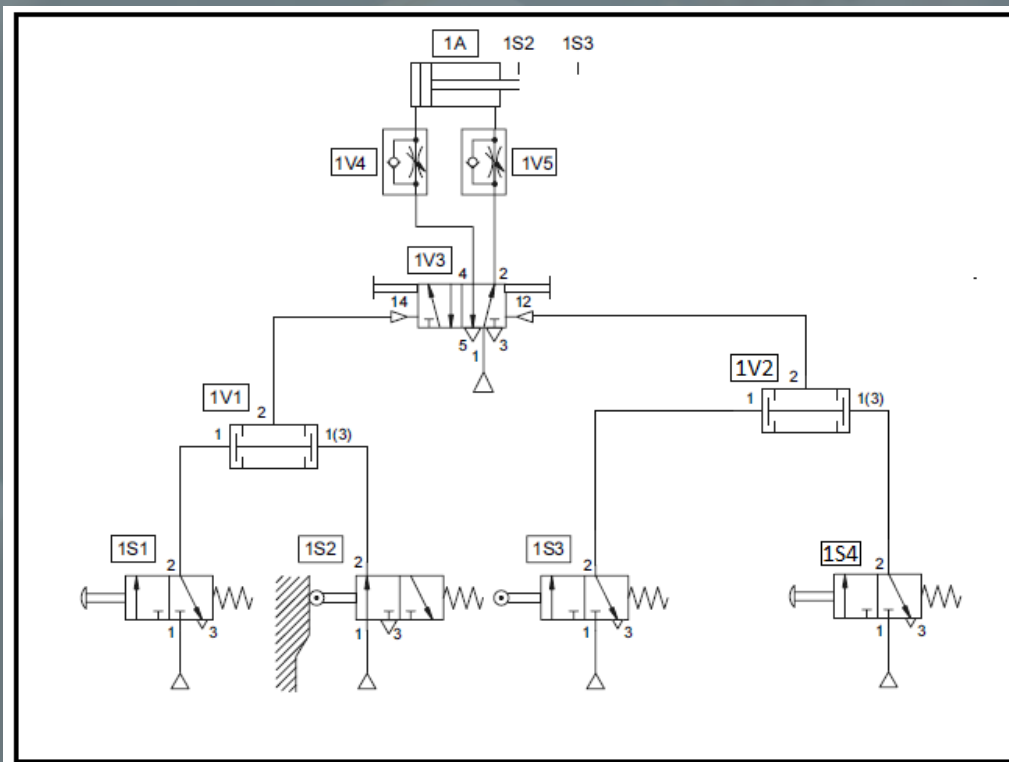

Figure 16: The Solution of Double Acting Cylinder Circuit

2.2 Development of Multiple Cylinder Circuits

2.2 Development of Multiple Cylinder Circuits

2.2.1 Sequence control for numerous cylinder

a. Abbreviated notation

Is another possibility of representing motion sequences. In this case, the cylinder designations A, B, C, etc. are used in the sequence. In Figure 17 shows the notation. The sequence A+ B+ B- A- ; is to be read as follows: Cylinder A forward/extend, cylinder B forward, cylinder B retracts, followed by cylinder A retracts. Sequential movements are written consecutively.

The signal for Extending position is designated using a position '+' and the signal for retracting using a negative '-'. Hence, a small letter (a1, a2, b1, b2) representing a roller switch or limit switch.

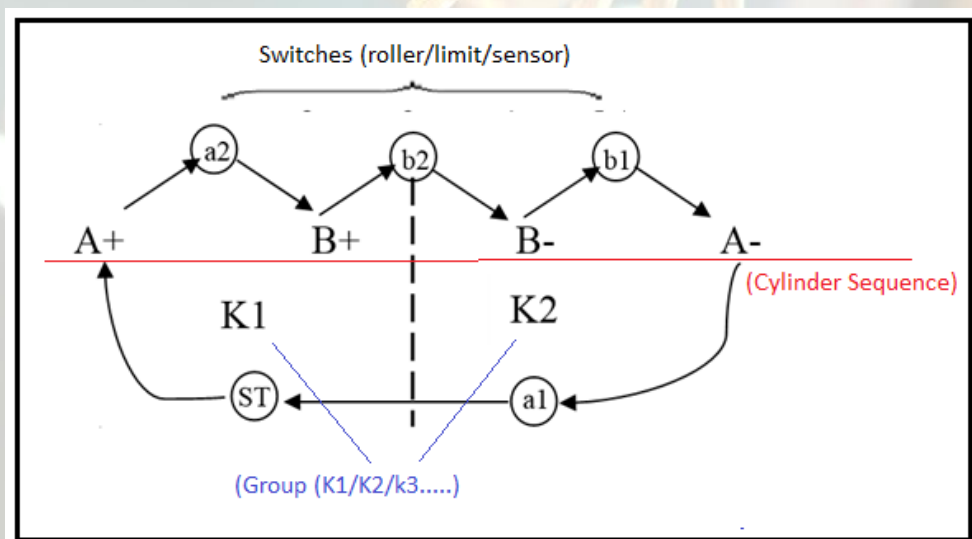
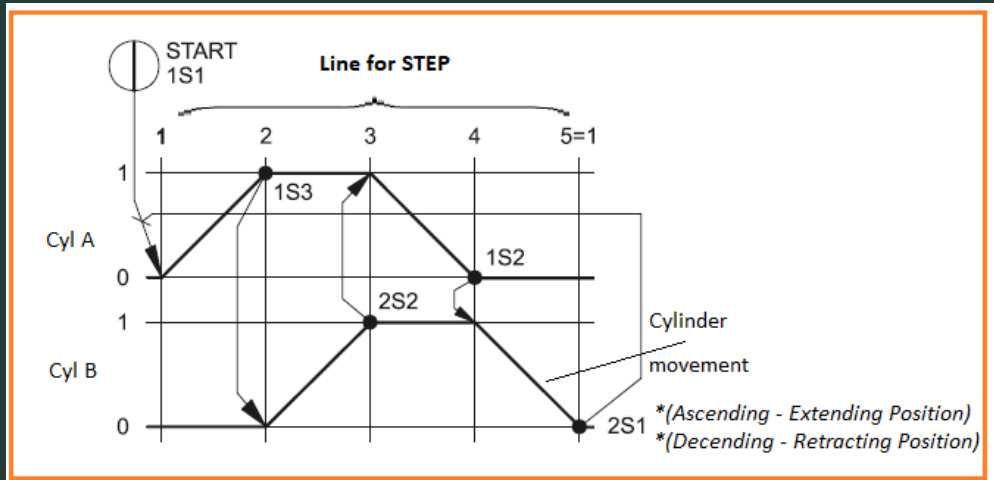

Figure 17: Abbreviated Notation of The Sequence Circuit

b. Motion / Displacement step diagram



c. Displacement-Time - Diagram

- In the case of a displacement-time diagram, the displacement is plotted in relation to the time.

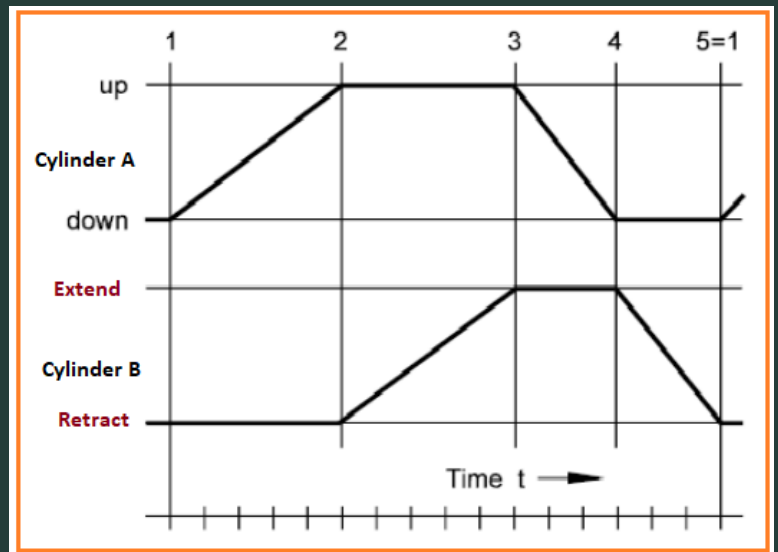
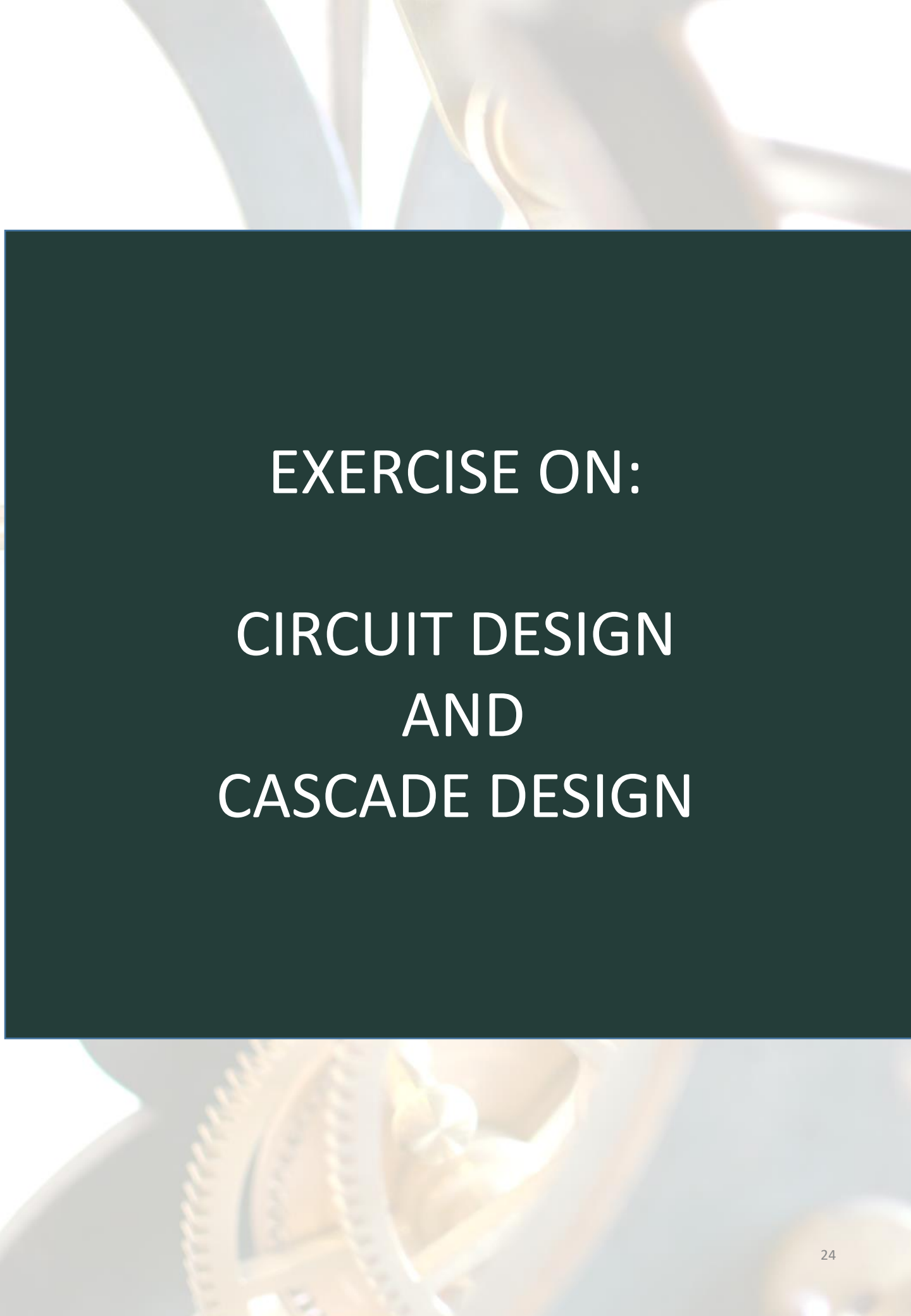

Figure 18: Displacement Step & Time Diagram



EXERCISE ON:
CIRCUIT DESIGN
AND
CASCADE DESIGN

Example 1:

2.2.2 Circuit solution for overlapping signals a. Roller lever valve with Idle return solution

Two cylinders (Fig 19) are used to transfer parts from a magazine onto a chute.

When a push button is pressed, the first cylinder extends, pushing the part from the magazine and positions it in preparation for transfer by the second cylinder onto the outfeed chute. Once the part is transferred, the first cylinder retracts, followed by the second. (*Festo Didactic*)

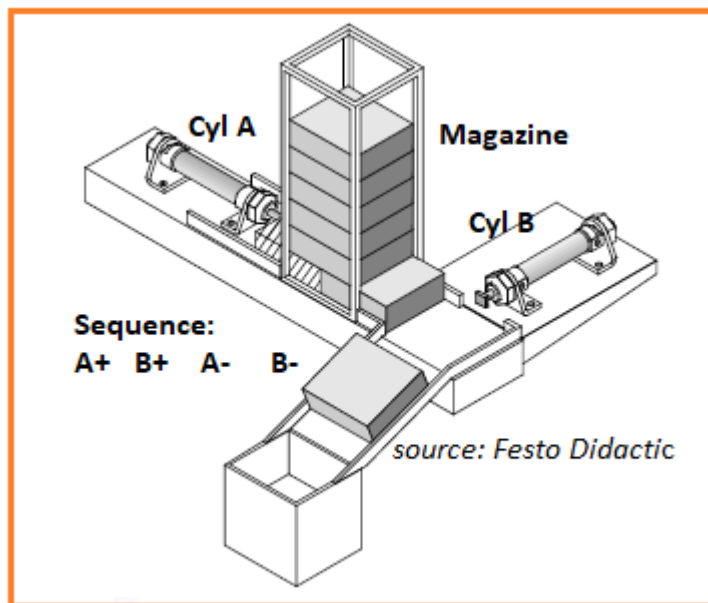
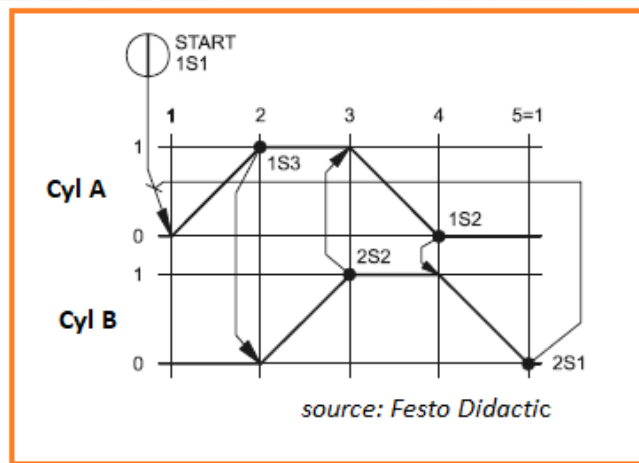

Figure 19: The Sequence Motion

Solution:

- i. Propose a sequence diagram.



- i. Setup a complete circuit diagram of pneumatic systems.

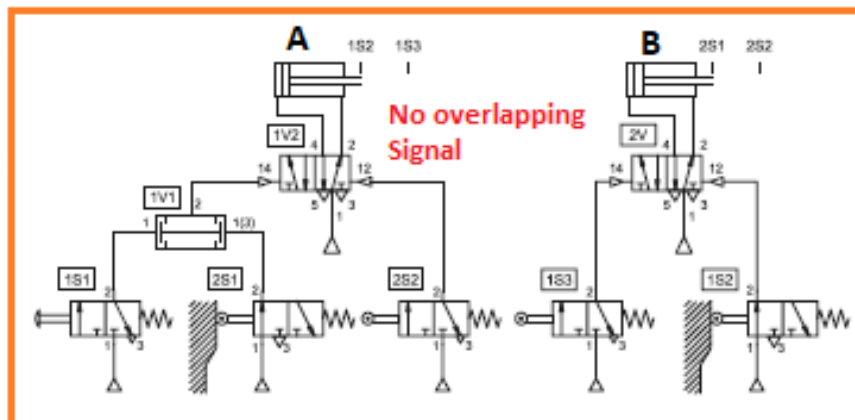

Figure 20: The Sequence Diagram (without overlapping)

Example 2:

- 2.2.2 Circuit solution for overlapping signals
- Roller lever valve with Idle return solution

A clamping system (double acting cylinder, (A) and drilling (double acting cylinder, B) function as follows. When the switch is pressed, the clamps will clamp and drill the work piece. Once completed, the drill will stopped and reversed. Finally, the clamps will release the work piece. The limit of start and extend position of the clamps and drills are determined by the limit switch a0 and a1 for clamping system and b0 and b1 for drilling respectively.

Solution:

- Propose a sequence diagram.

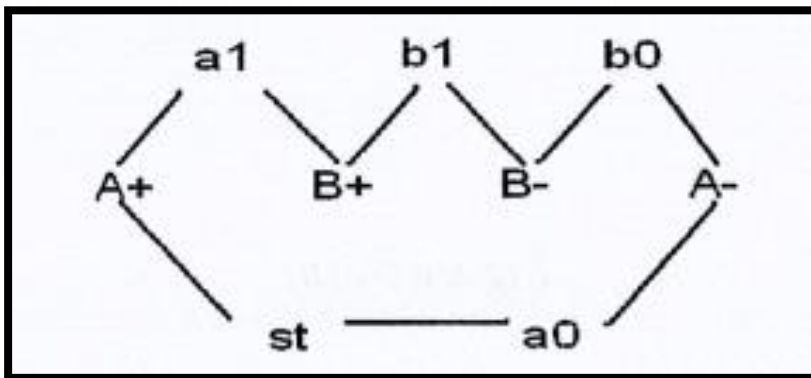

Figure 21: The Sequence Diagram

Solution:

- 2.2.2 Circuit solution for overlapping signals
 - a. Roller lever valve with Idle return solution

Solution:

- i. Setup a complete circuit diagram of pneumatic systems as in Fig 22.

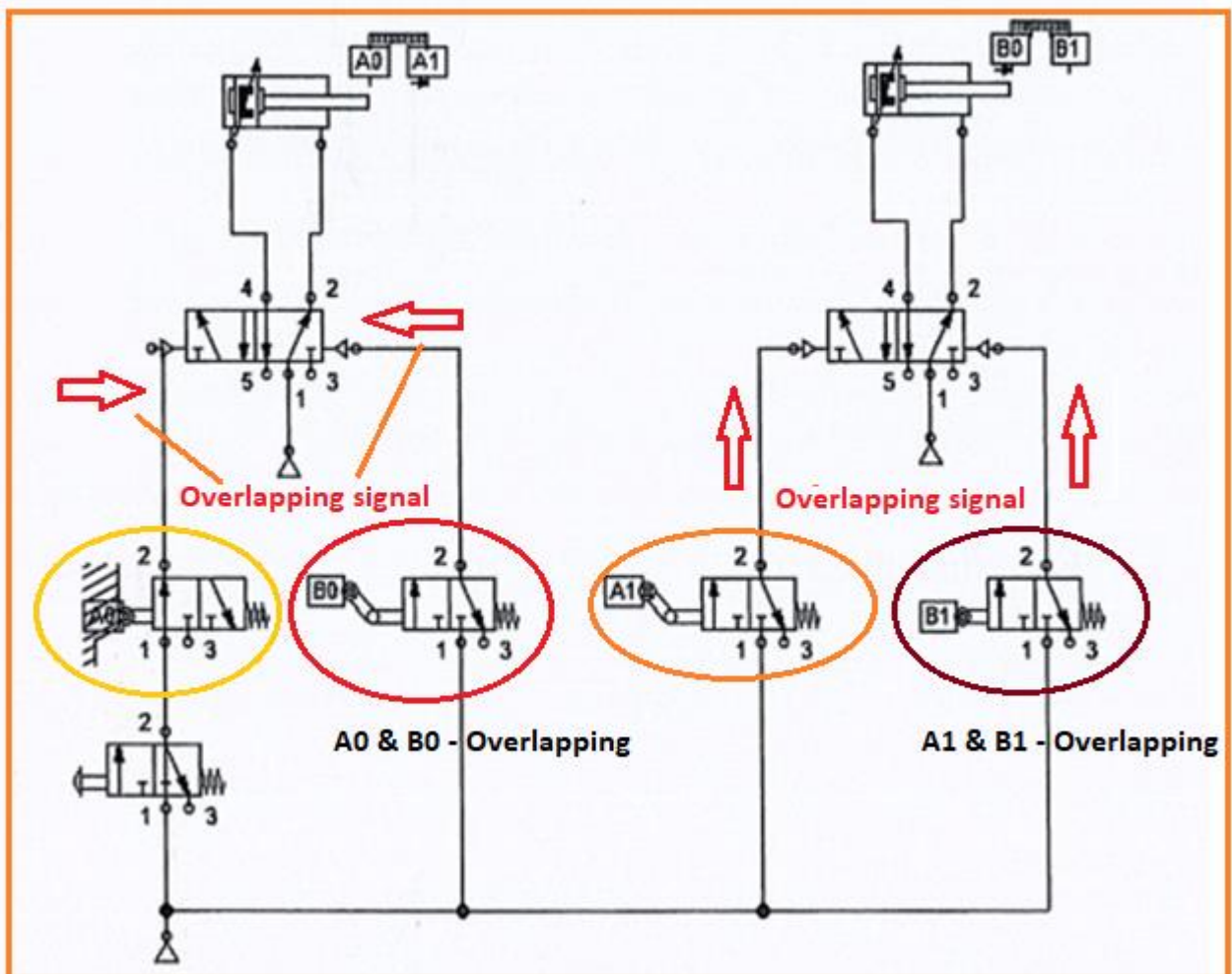

Figure 22: The Solution of The Sequence Circuit (with overlapping signal)



PNEUMATICS CIRCUIT DESIGN

b. CASCADE METHOD



How to Develop Multiple-actuator Pneumatic Circuits Using the Cascade Method?

STEP OVERVIEW:

- STEP 1 - Draw a notational form of the Control Task and group of cascade
- STEP 2- Draw a displacement-step Diagram
- STEP 3 - Developing the Power Circuit
- STEP 4 - Draw the group supply to change of group 2, 3 or 4
- STEP 5 - Circuit Position during the A+ B+ B- A-

PROBLEM

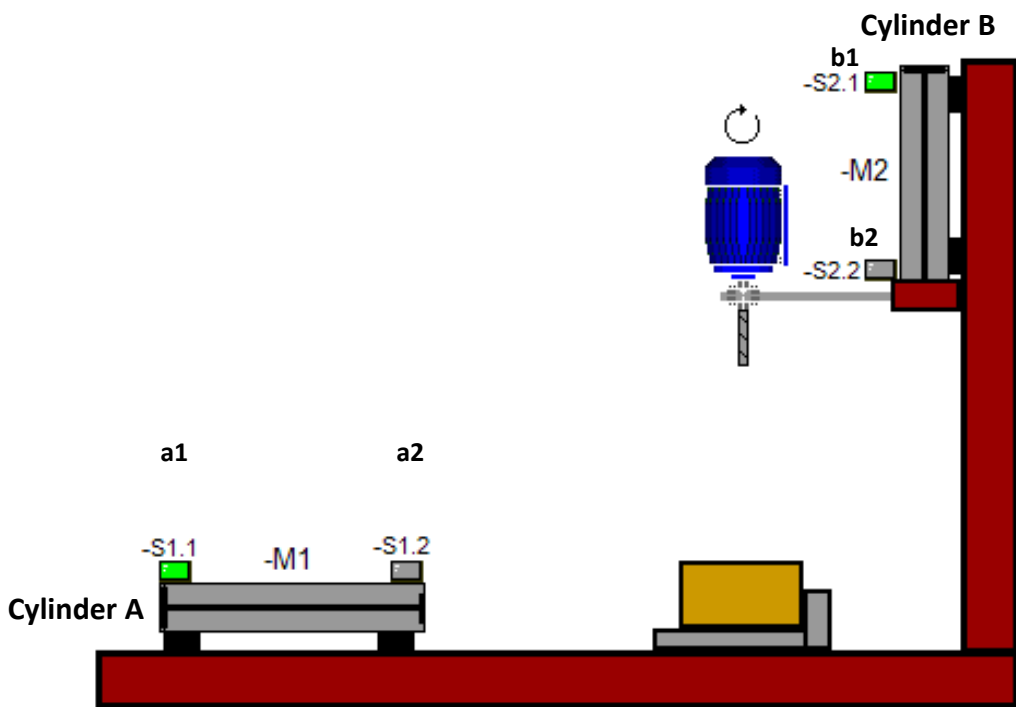
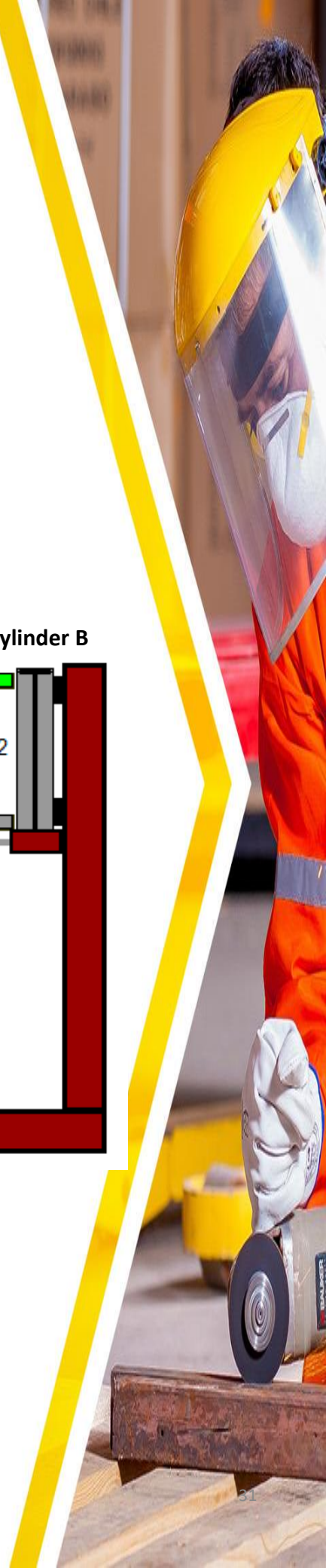

Figure 23: The Application of Pneumatic



Group of Pneumatics Sequence

Draw a notational form of the Control Task and group of cascade

- The sequence of operations of cylinders, that is, **A+ B+ B- A-** are divided into appropriate groups in such a way that there is no possibility of a signal conflict.
- Remember, **A+ and A-** can't be in the same group, there is a possibility of signals appearing simultaneously at both ends of the final control element.
- Similarly, **B+ and B-** can't be in the same group, there is a possibility of signals appearing simultaneously at both ends.
- Hence, the sequence of operations is divided in such a way that the A+ and A- actions fall into different groups (K1 and K2), and the B+ and B- actions fall into different groups (K1 and K2), as demonstrated.

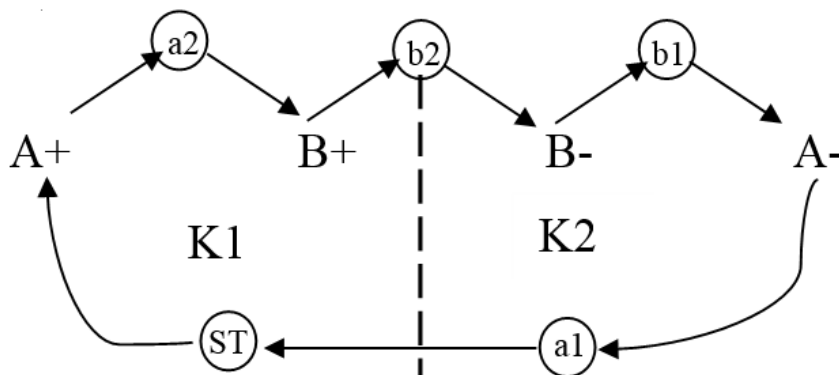
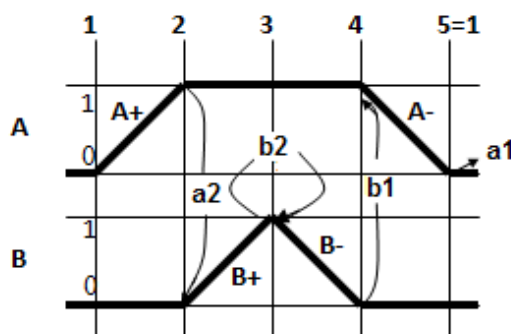

Figure 24: The Abbreviated Notation and Group

Draw a Displacement-step Diagram

- A displacement step diagram illustrates how the sequence of movements of the pneumatic control system functions in a clear and easily understood fashion.
- The individual movements of all the working components are plotted along an axis that shows the individual steps (Step 1 to 5 as example).
- The displacements of cylinders are plotted in accordance with the required sequence of the cylinder actions in equal steps.
- The displacement of any cylinder from the **retracted position (0)** to the **extended position (1)** is shown in the diagram with a line from 0 to 1.



Displacement Step-Diagram

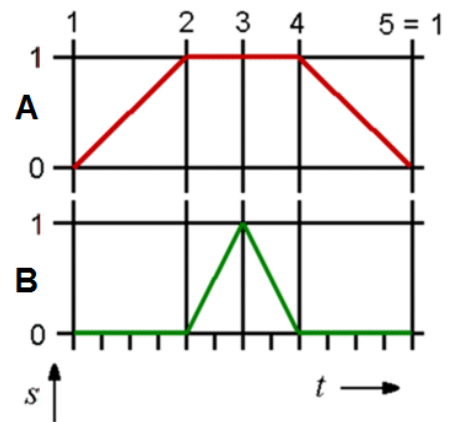

Timing Diagram

Figure 25: The Displacement Step & Time Diagram

Developing The Power Circuit

- The designing of a circuit diagram for the control task is to draw the power circuit with the cylinders, final control elements, and properly designated sensors. Two 5/2-way double-pilot valves act as final control elements to control the cylinders A and B respectively.
- For the automatic operation of the desired sequence, a pair of sensors is used per cylinder to confirm the end positions of the piston. Sensors a1 and a2 are positioned in the retracted and extended positions respectively of the cylinder A.
- Similarly, sensors b0 and b1 (or B0 and B1) are positioned in the retracted and extended positions respectively of the cylinder B. The partial circuit with the cylinders, the final control elements, and the sensors are shown in the figure.

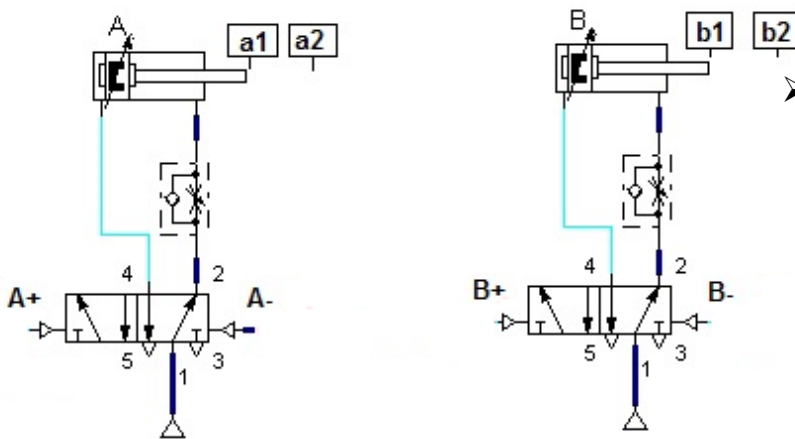

- The entire sequence of the cylinder actions and the associated sensor outputs can be represented in a notational form before developing the control circuit. The developed circuit is then checked for the presence of signal conflicts.

Figure 26: Development of Power Circuit

Developing The Power Circuit

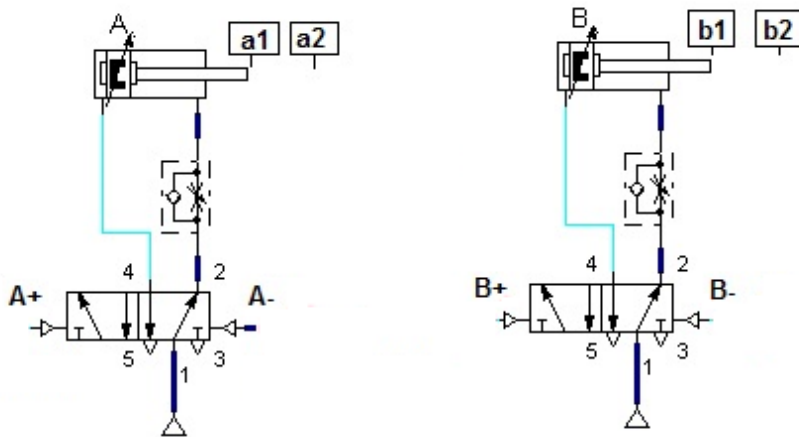

- The entire sequence of the cylinder actions and the associated sensor outputs can be represented in a notational form before developing the control circuit. The developed circuit is then checked for the presence of signal conflicts.

Figure 27: Development of Power Circuit

Draw the group supply to
change of group 2, 3 or 4

- Divide the power supply for the control circuit into an equal number of groups in such a way that at any given point in time, only one group will have the supply with all other group(s) connected to the exhaust.
- By an appropriate interconnection of the 5/2-DC valves, the power supply can be divided into 2 groups, 3 groups, 4 groups etc.
- It should be remembered that the desired sequence should be maintained. In this method, every attempt should be made to keep the number of groups to a minimum so as to keep the number of valves to a minimum.

2 GROUP

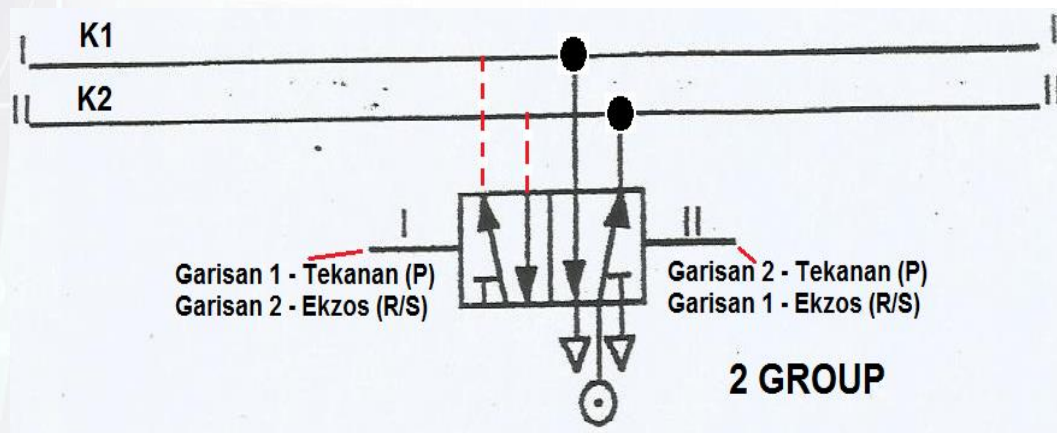
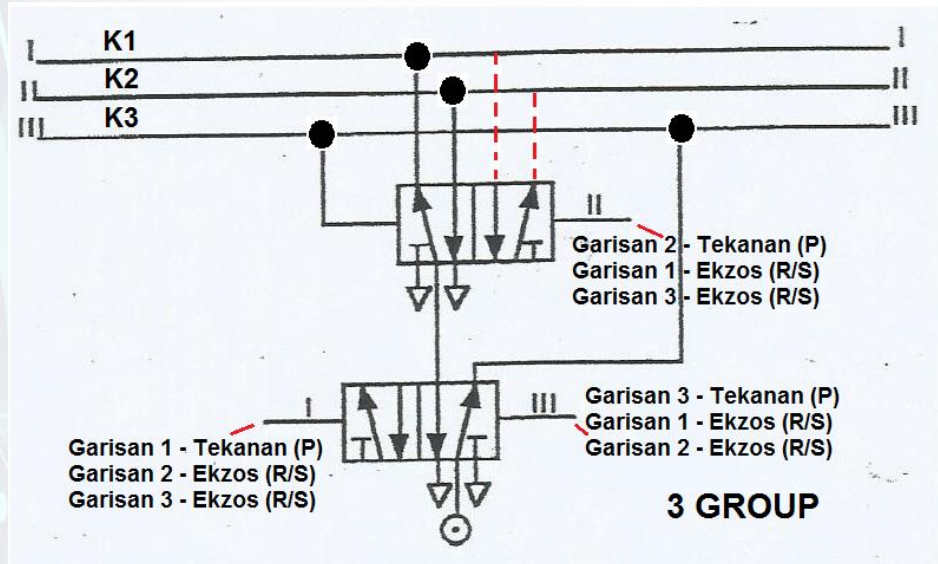

Figure 28: The Development of Group 2, 3 or 4

Draw the group supply to
change of group 2, 3 or 4

3 GROUP



4 GROUP

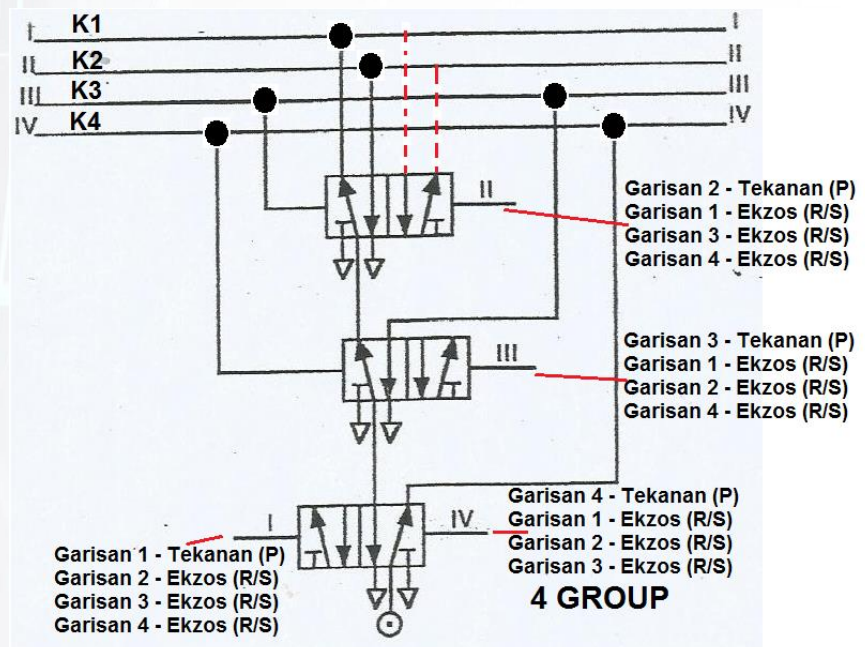
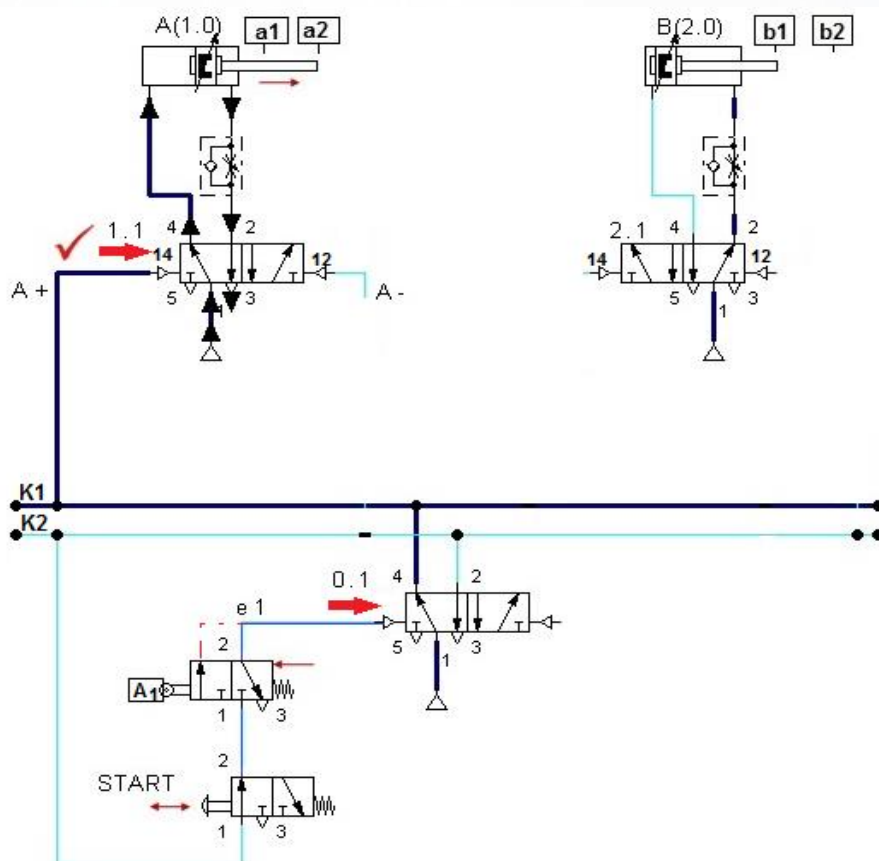

Figure 29: The Development of Group 2, 3 or 4

Circuit Position during the A+ B+ B- A-

- When the “Start” pushbutton is pressed, the air supply from the group G2 is directed to the port 14 of the reversing valve 0.1 through the “Start” pushbutton and the actuated sensor a0.
- The reversing valve switches over causing the group supply to change from the group G2 to G1. (Note: a0 is shown in the released position due to the subsequent extension of cylinder A).
- When the group is changed from the group G2 to G1 with the group G2 vented, the air supply from the group G1 is directed to port 14 of the valve 1.1. As there is no possibility of a signal conflict here, the valve 1.1 switches over causing the A+ action.



**Circuit Position
during the A+
Action**

Figure 30: The Circuit Positioning

Circuit Position during the A+ B+ B- A-

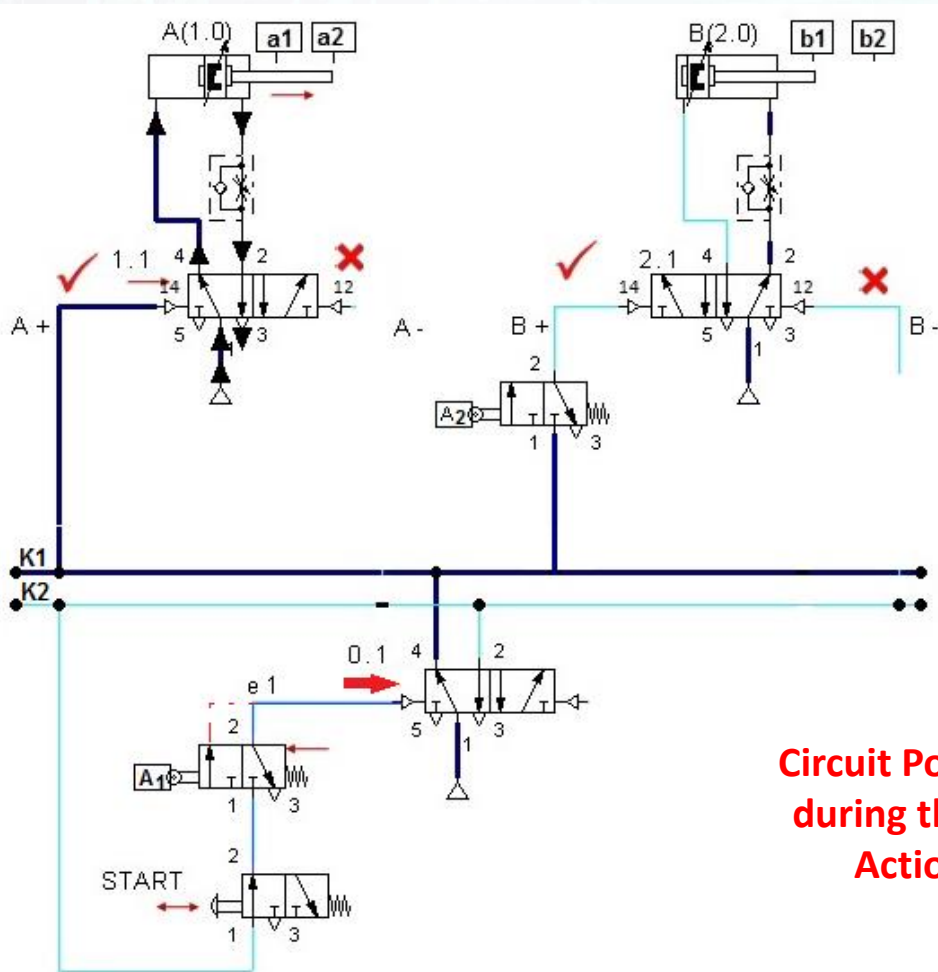

**Circuit Position
during the B+
Action**

Figure 31: The Circuit Positioning

Circuit Position during the A+ B+ B- A-

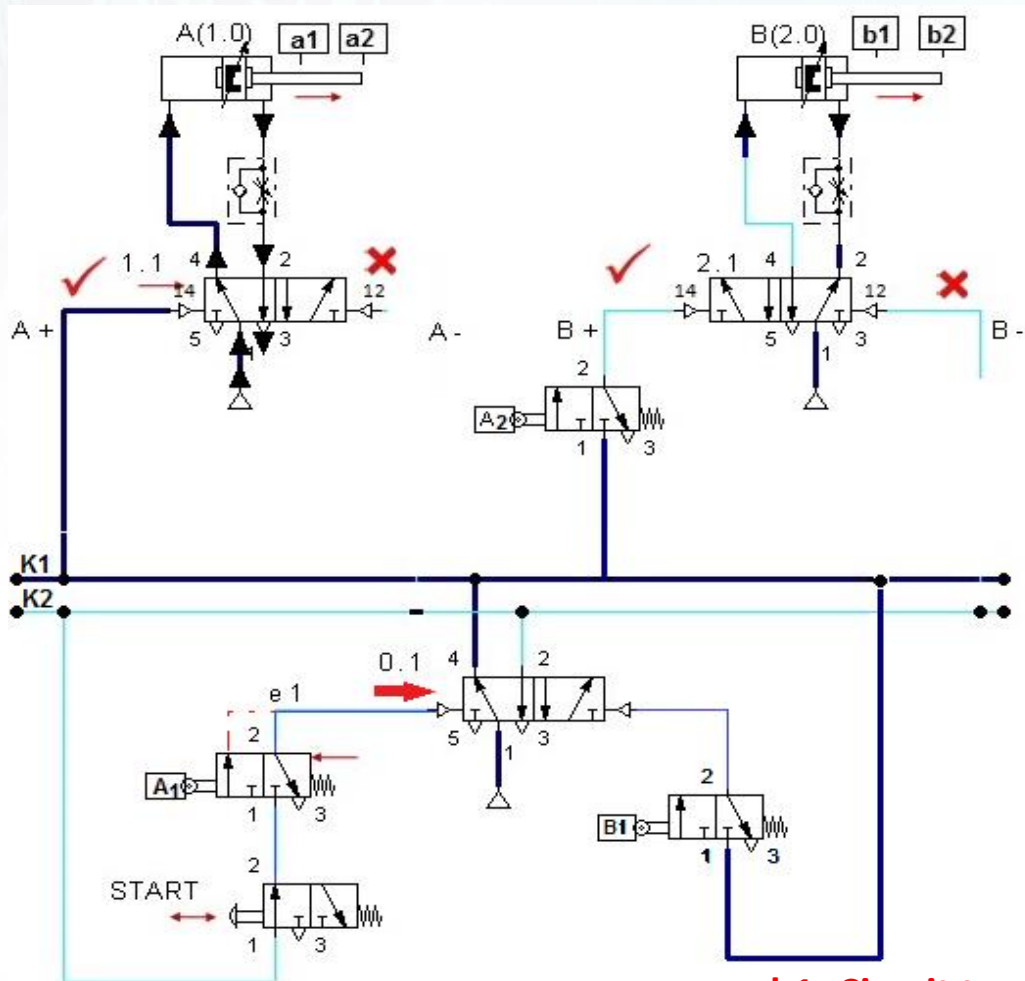

b1- Circuit to change power line from Group 1 (K1) to Group 2 (K2)

Figure 32: The Circuit Positioning

Circuit Position during the A+ B+ B- A-

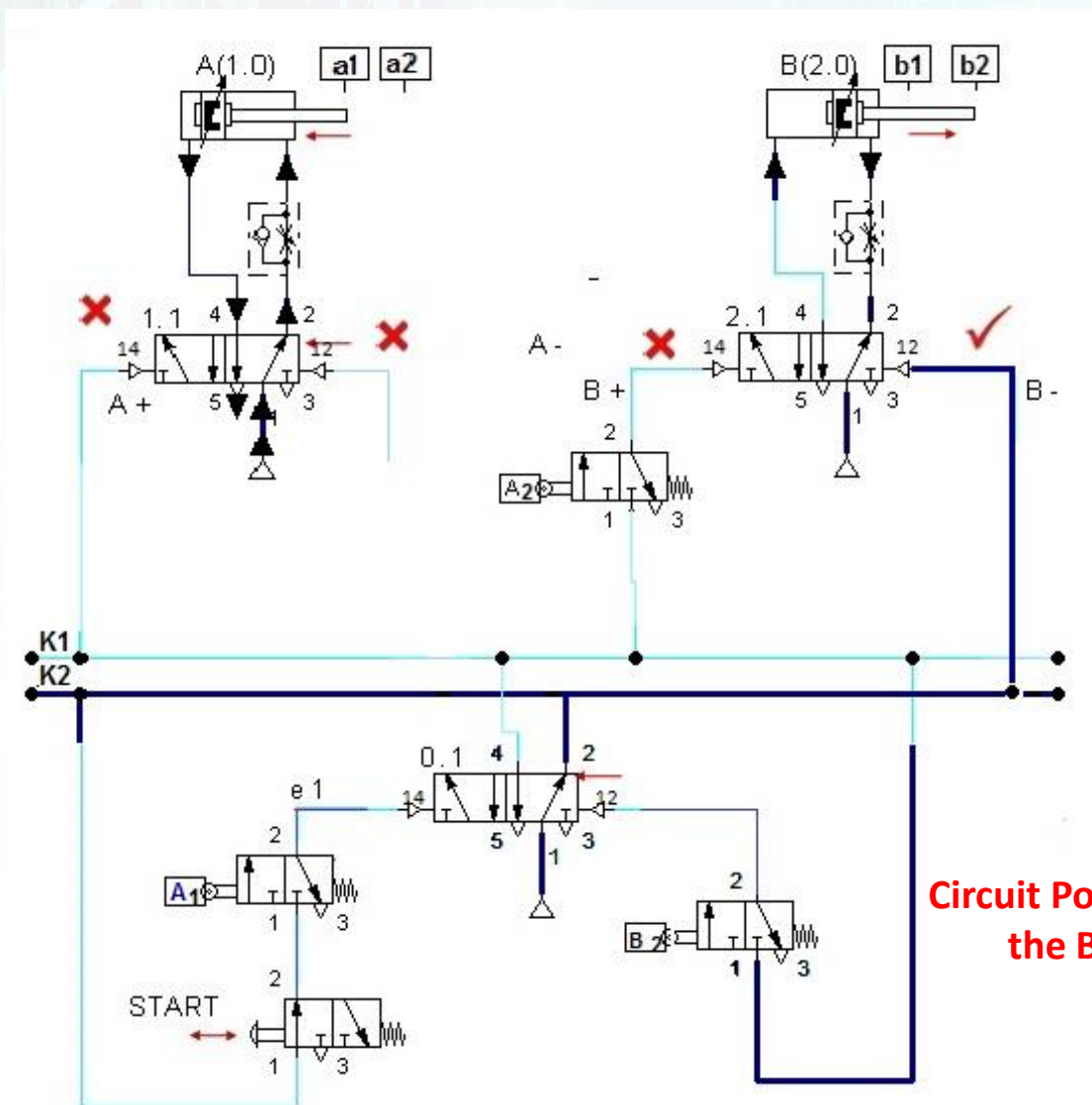

Circuit Position during the B- Action

Figure 33: The Circuit Positioning

Circuit Position during the A+ B+ B- A-

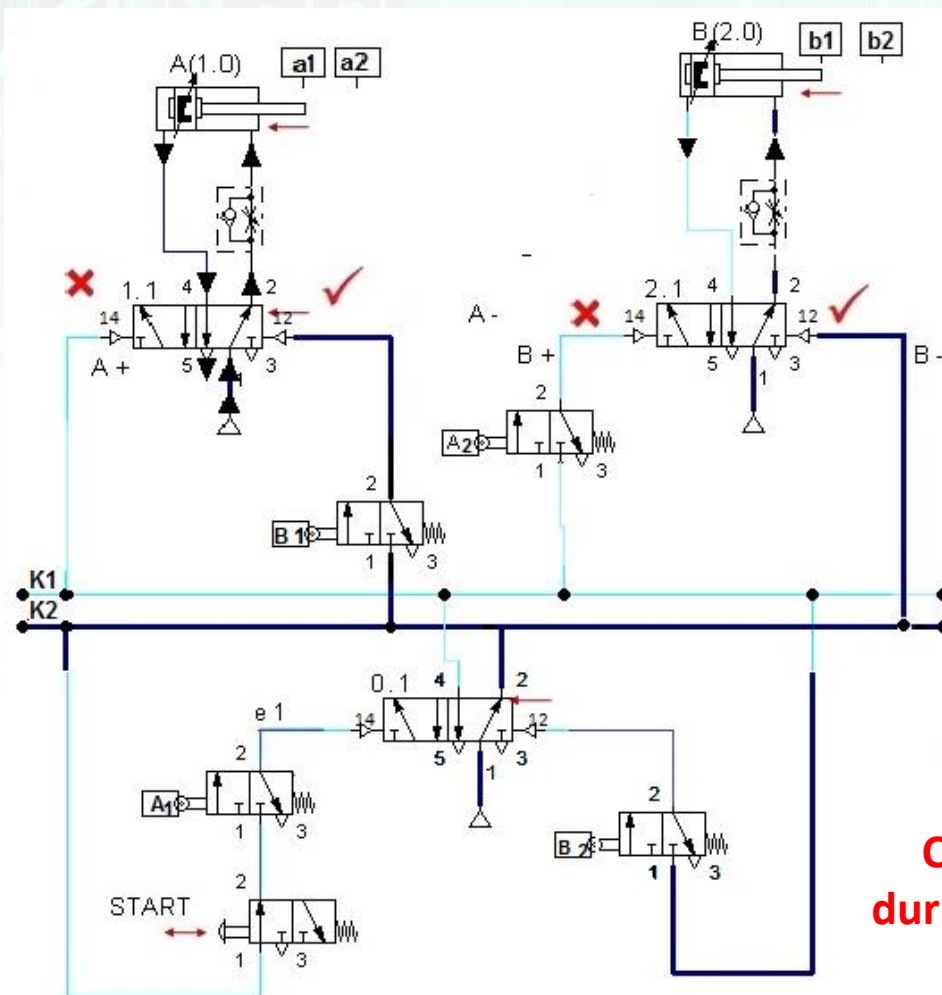

Figure 34: The Circuit Positioning (Complete Circuit)

THE SEQUENCE OF THE PNEUMATICS CIRCUIT - COMPLETED

PROBLEM

A transfer system, consist of two cylinder double acting cylinder. Cylinder A will push part from the magazine, then back to its start position. The Cylinder B start moving forward when the Cylinder A fully retract. The Cylinder B only retract when the component is fully transferred onto the transfer box. The cycle is to start when a start button is pressed.

EXERCISE

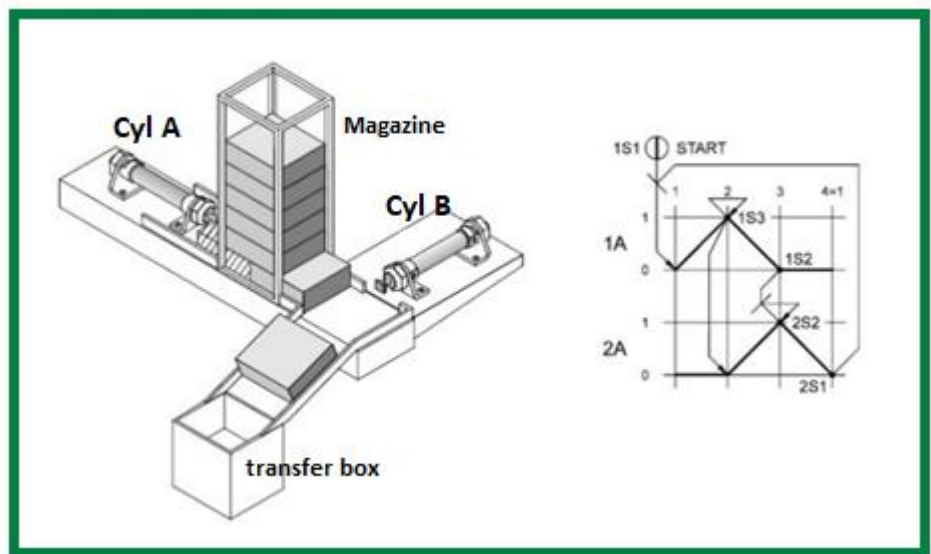
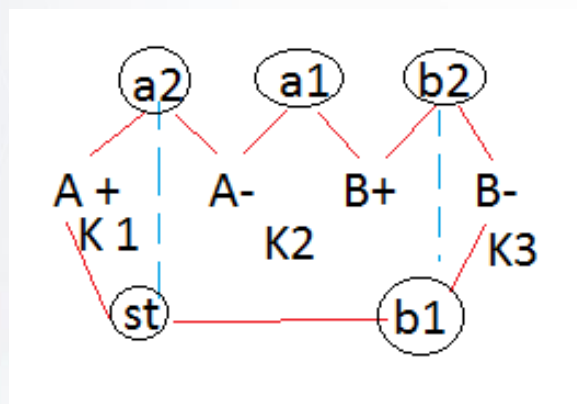

Figure 35: The Application of Pneumatic Circuit

SOLUTION

EXERCISE

STEP 1 - A Group of Pneumatics Sequence



STEP 2 - Draw a Displacement-Step Diagram

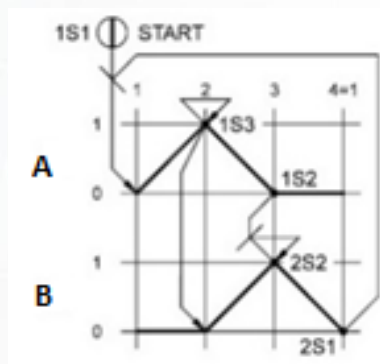
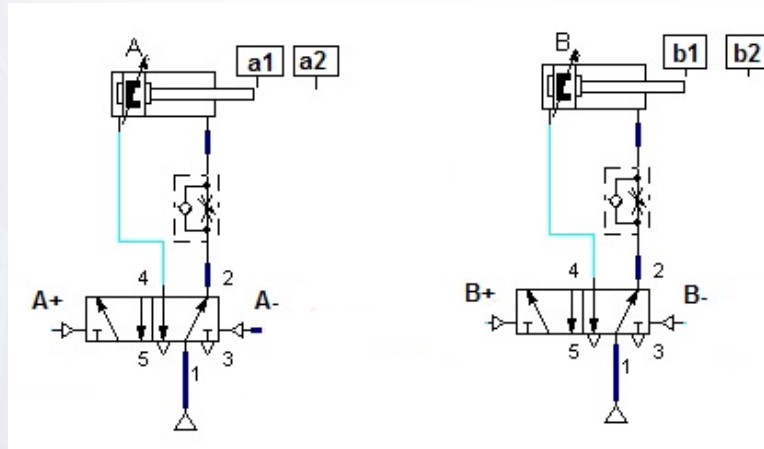

Figure 36: Draw a Group and Step Diagram

STEP 3 – Developing Power Circuit



STEP 4 - Draw the group supply to change of group 2, 3 or 4

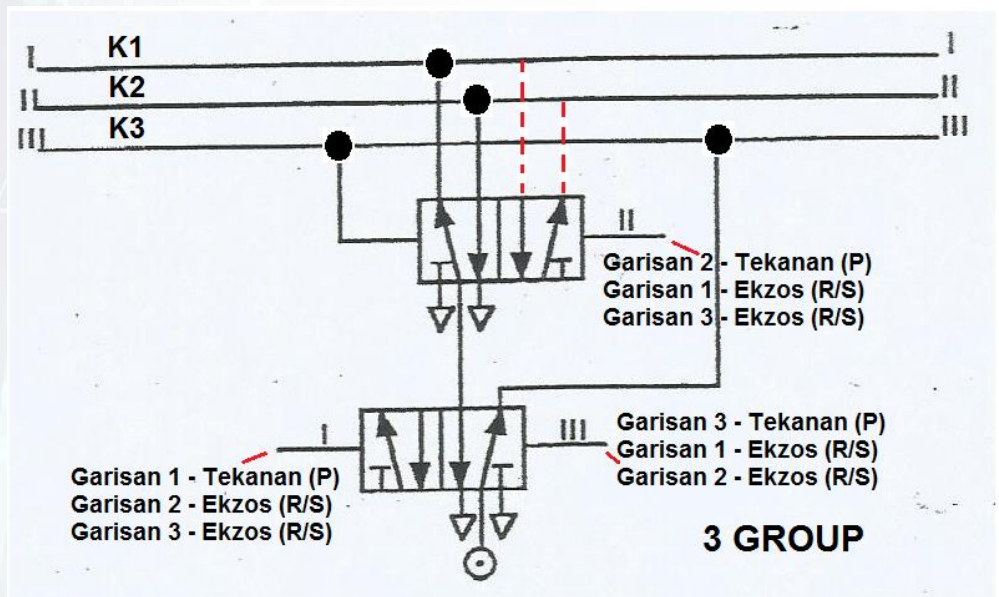

Figure 37: The Group of 3

STEP 5 – Develop a Circuit Position For A+ A- B+ B-

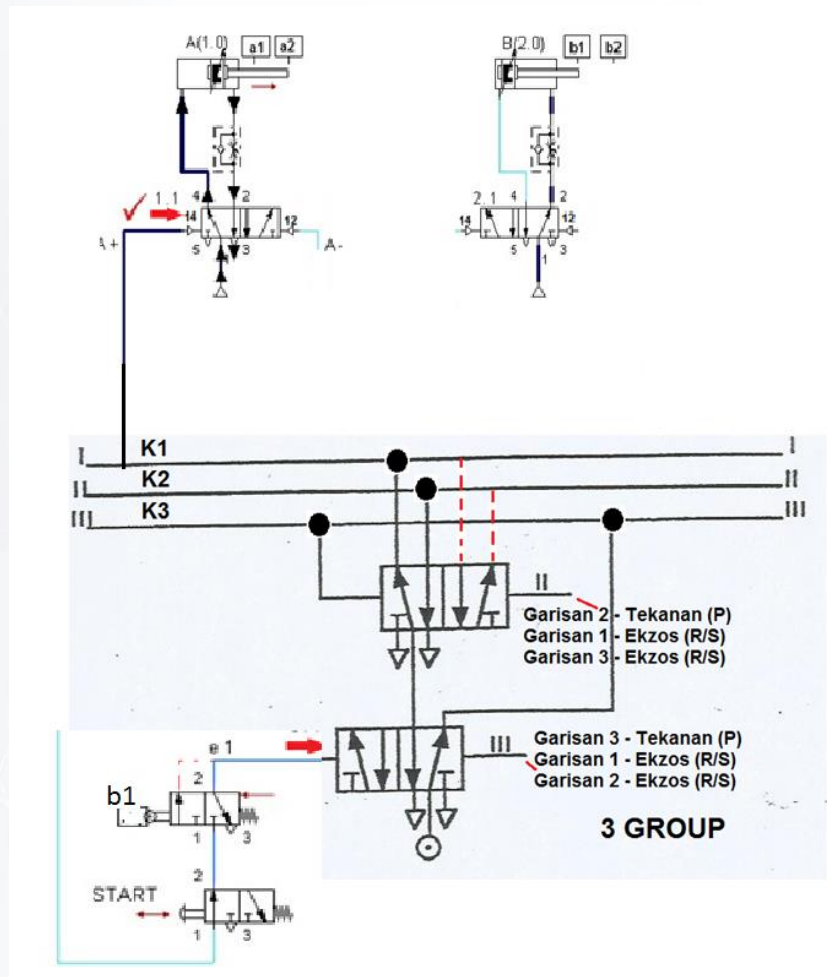

Figure 38: The Development of Circuit Positioning

SOLUTION

EXERCISE

STEP 5 – Develop a Circuit Position For A+ A- B+ B-

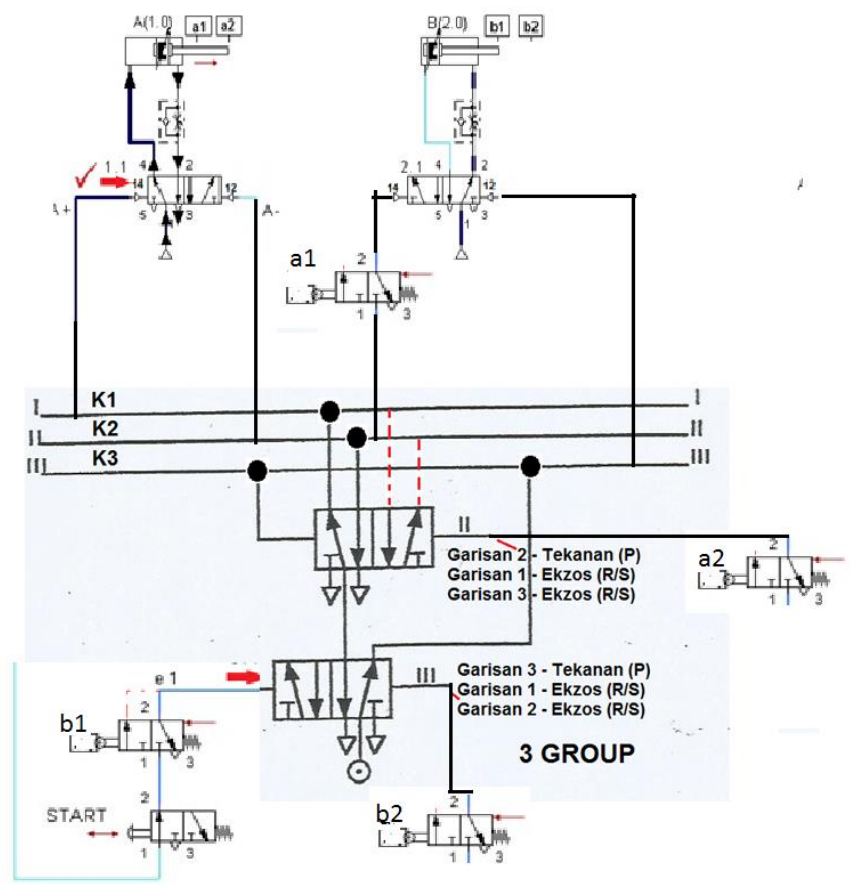

Figure 39: A Complete Circuit

REFERENCES

1. Ebel F. (2013). Pneumatics Basic Level, Festo Didactic GmbH & Co. KG, D-73770Denkendorf, Germany
2. Totten G.E & De Negri V.J (2017). Handbook of Hydraulic Fluid Technology,Second Edition. Taylor & Francis Group.
3. The Pneu Book, SMC Pneumatics (UK) Ltd
4. Ilango Sivaraman (2017). Introduction to Hydraulics and Pneumatics, 3rd Ed. PHI Learning Pvt. Ltd. Delhi.
5. SMC Pneumatics (Australia) Pty Ltd (1996). SMCT.P1 Pneumatic Technology 1 Textbook
6. SMC Pneumatic (Hongkong) Limited. SMCT. C.A.T. P1, SMC Training Software.



DR MOHD ELIAS BIN DAUD

He is started his career as lecturer in Mechanical Engineering since 1999 at Polytechnic Sultan Salahuddin Abd. Aziz Shah. Graduated in Bachelor Degree of Electro Mechanical from UTM dan finished his PhD in Manufacturing System from UTHM. Experience in Teaching in Automation System, Pneumatic and Hydraulic Technology for more than 15 years. Also involved in Curriculum Development in Mechatronic Engineering.



NAZRATULHUDA BT AWANG @ HASHIM

She is started his career as a lecturer in Mechanical Engineering in 2001 at Polytechnic. She graduated with a Bachelor's Degree in Material Engineering from USM. She finished his Masters in Engineering of Manufacturing System from UKM. Experience in Teaching in Pneumatic and Hydraulic Technology for more than 15 years..



Terbitan:

POLITEKNIK
MALAYSIA
SULTAN SALAHUDDIN ABDUL AZIZ SHAH

e ISBN 978-967-2044-85-7



9 789672 044857