

SULIT



**BAHAGIAN PEPERIKSAAN DAN PENILAIAN
JABATAN PENDIDIKAN POLITEKNIK DAN KOLEJ KOMUNITI
KEMENTERIAN PENGAJIAN TINGGI**

JABATAN KEJURUTERAAN ELEKTRIK

PEPERIKSAAN AKHIR

SESI II : 2021/2022

DET10013: ELECTRICAL TECHNOLOGY

TARIKH : 01 JULAI 2022

MASA : 8.30 PAGI – 10.30 PAGI (2 JAM)

Kertas ini mengandungi **TUJUH (7)** halaman bercetak.

Bahagian A: Struktur (3 soalan)

Bahagian B: Esei (1 soalan)

Dokumen sokongan yang disertakan : Tiada

JANGAN BUKA KERTAS SOALAN INI SEHINGGA DIARAHKAN

(CLO yang tertera hanya sebagai rujukan)

SULIT

SECTION A : 75 MARKS
BAHAGIAN A : 75 MARKAH

INSTRUCTION

This section consists of **THREE (3)** structured question. Answer **ALL** questions.

ARAHAN:

Bahagian ini mengandungi TIGA (3) soalan struktur. Jawab SEMUA soalan.

QUESTION 1

SOALAN 1

CLO1
C3

- (a) Based on the total e.m.f calculation shown below, draw the series cell connection.
Berdasarkan maklumat pengiraan jumlah e.m.f di bawah. Lukiskan litar sambungan bateri secara siri.

i.
$$V_T = -V_1 + V_2 - V_3$$

$$= -6 + 8 - 3$$

ii.
$$V_T = V_1 + V_2 + V_3 - V_4 - V_5$$

$$= 4 + 3 + 8 - 5 - 1$$

iii.
$$V_T = 15(3)$$

iv.
$$V_T = V_1 + V_2 + V_3 + V_4$$

$$= 10 + 10 + 10$$

[8 marks]
[8 markah]

CLO1
C3

- (b) Based on Figure 1(b) below, calculate:
 i. Current, I_1
 ii. Current, I_2
 iii. Resistor, R

Berdasarkan Rajah 1(b) di bawah, kira:

- i. Arus, I_1
 ii. Arus, I_2
 iii. Rintangan, R

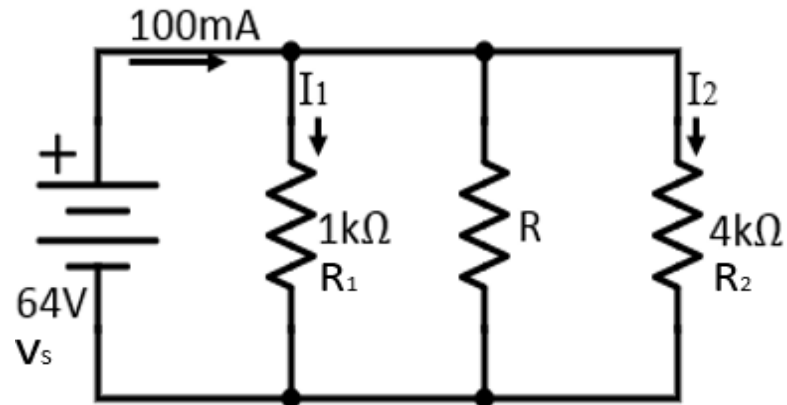
Figure 1(b) / *Rajah 1(b)*

[8 marks]
[8 markah]

CLO1
C3

(c) Based on Figure 1(c) below, calculate:

- Total resistance, R_T
- Total Current, I
- Current, I_1

Berdasarkan *Rajah 1(c)* di bawah, kira:

- Jumlah rintangan, R_T
- Jumlah arus, I
- Arus, I_1

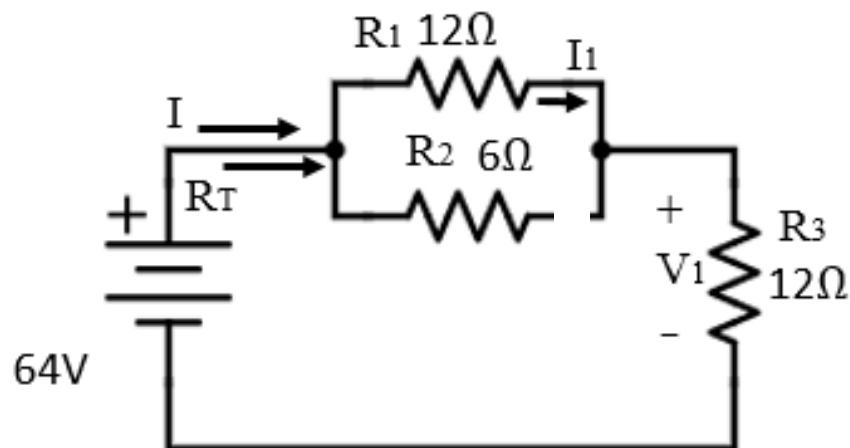
Figure 1(c) / *Rajah 1(c)*

[9 marks]
[9 markah]

QUESTION 2

SOALAN 2

CLO1
C3

- (a) Refer to Figure 2(a), solve the circuit by using Star-Delta Transformation.
Merujuk kepada Rajah 2(a), selesaikan litar menggunakan Star-Delta Transformasi.

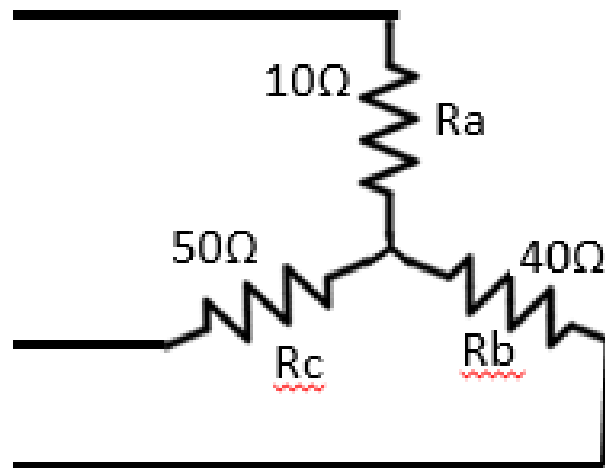

Figure 2(a) / Rajah 2(a)

[8 marks]
[8 markah]CLO1
C3

- (b) Based on Figure 2(b) below, simplify the circuit to obtain the total capacitors.
Berdasarkan Rajah 2(b) di bawah, permudahkan litar tersebut untuk mendapatkan jumlah kapasitor.

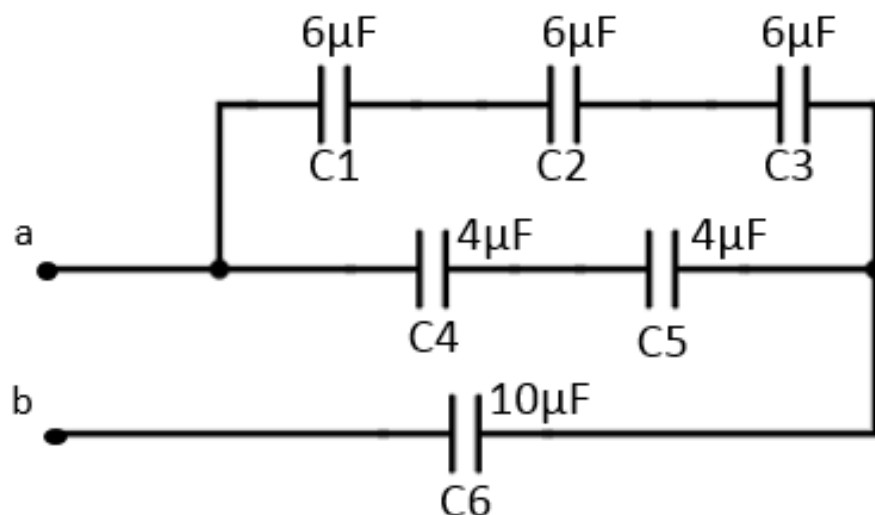

Figure 2(b) / Rajah 2(b)

[8 marks]
[8 markah]

CLO1
C3

- (c) A capacitor with a capacitance of $40\mu\text{F}$ which connected in series to a $200\text{k}\Omega$ resistor is being placed with 300V DC voltage supply. Calculate the initial current, initial potential difference across capacitor, the time constant during charging, potential difference (V_c) when the capacitor is charged for 4s and the maximum energy stored in the capacitor.

Suatu pemuat $40\mu\text{F}$ disambung secara sesiri dengan perintang $200\text{k}\Omega$ dan ditempatkan merentasi bekalan voltan AT 300V . Kirakan arus permulaan, beza keupayaan permulaan merentasi pemuat, pemalar masa semasa mengecas, beza keupayaan (V_c) bila pemuat dicas 4 saat dan tenaga maksima yang disimpan dalam pemuat.

[9 marks]
[9 markah]

QUESTION 3

SOALAN 3

CLO1
C3

- (a) Refer to Figure 3(a), calculate the total inductance of the circuit between point a and b.

Merujuk kepada Rajah 3(a), kirakan jumlah kearuhan di antara titik a dan b.

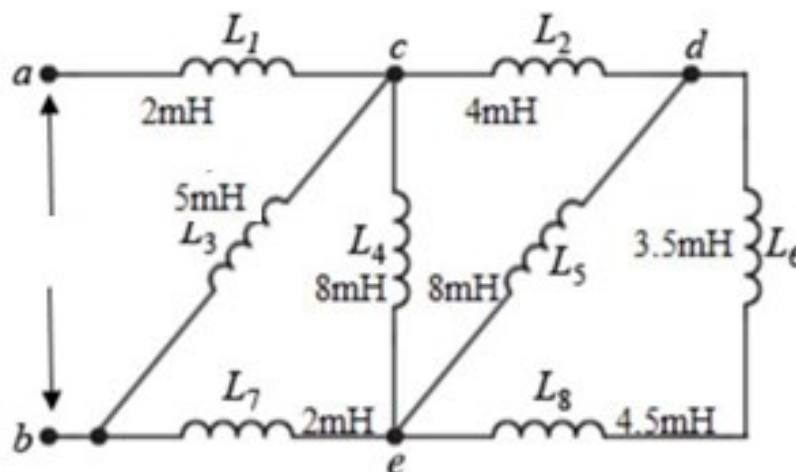

Figure 3(a) / Rajah 3(a)

[8 marks]
[8 markah]

- (b) Refer to Figure 3(b), calculate the inductor current after the switch is closed for $30\mu\text{s}$.

Merujuk kepada Rajah 3(b), kirakan arus yang melalui peraruh selepas $30\mu\text{s}$ suis ditutup.

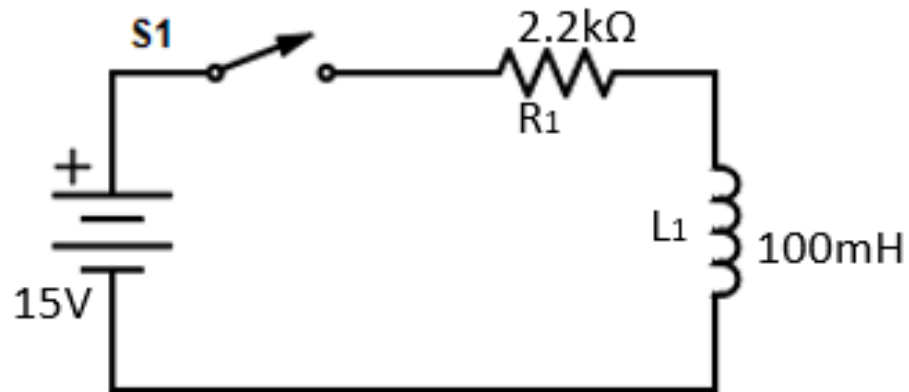

Figure 3(b) / Rajah 3(b)

[8 marks]

[8 markah]

CLO1
C3

- (c) A steel magnet circuit has a uniform cross-sectional area of 5cm^2 and length of 30cm . A coil of 200 turns is wound uniformly over the magnetic circuit. When the current in the coil is 2A , the total flux is 0.5mWb . Based on this condition, calculate the magnetic field strength and the relative permeability of steel.

Sebuah litar magnet keluli mempunyai keratan rentas seragam sebanyak 5cm^2 yang panjangnya 30cm . Sebanyak 200 lilitan gegelung dililitkan secara seragam pada litar tersebut. Apabila arus sebanyak 2A dialirkan pada litar didapati jumlah fluks 0.5mWb telah terhasil. Berdasarkan keadaan ini, kirakan kekuatan medan magnet dan kebolehtelapan relatif bagi keluli.

[9 marks]

[9 markah]

SECTION B : 25 MARKS
BAHAGIAN B : 25 MARKS

INSTRUCTION:

This section consists of **ONE (1)** essay question. Answer the question.

ARAHAN:

Bahagian ini mengandungi **SATU (1)** soalan esei. Jawab soalan tersebut.

QUESTION 1

SOALAN 1

CLO1
C3

Calculate the current flow through R in Figure 4 below when $R = 12\Omega$ by using Thevenin's Theorem.

Kirakan nilai arus yang mengalir melalui perintang R apabila $R = 12\Omega$ dari Rajah 4 di bawah dengan menggunakan kaedah Teorem Thevenin.

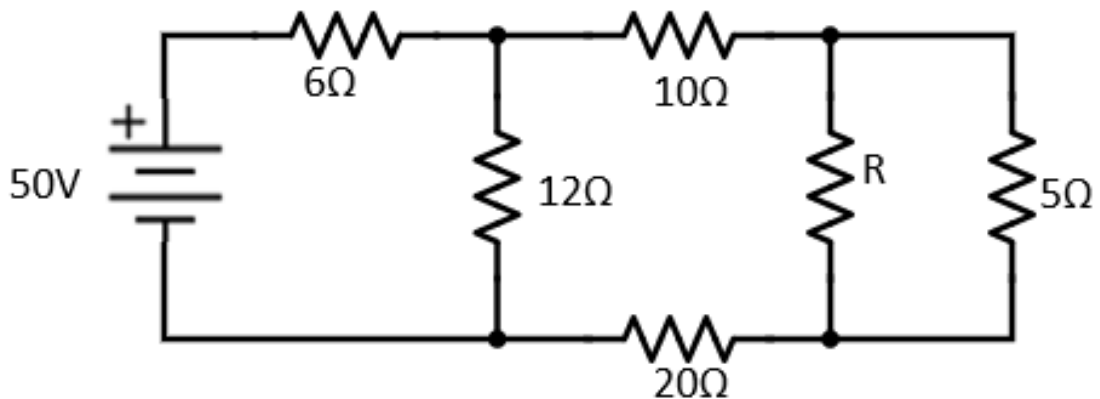

Figure 4 / Rajah 4

[25 marks]
[25 markah]

SOALAN TAMAT