

SULIT



**BAHAGIAN PEPERIKSAAN DAN PENILAIAN
JABATAN PENDIDIKAN POLITEKNIK DAN KOLEJ KOMUNITI
KEMENTERIAN PENGAJIAN TINGGI**

JABATAN KEJURUTERAAN ELEKTRIK

PEPERIKSAAN AKHIR

SESI I : 2022 / 2023

DEJ30023: INSTRUMENTATION

TARIKH : 22 DISEMBER 2022

MASA : 2.30 PM - 4.30 PM (2 JAM)

Kertas ini mengandungi **LAPAN (8)** halaman bercetak.

Bahagian A: Struktur (4 soalan)

Bahagian B: Esei (1 soalan)

Dokumen sokongan yang disertakan : Tiada

JANGAN BUKA KERTAS SOALAN INI SEHINGGA DIARAHKAN

(CLO yang tertera hanya sebagai rujukan)

SULIT

SECTION A: 80 MARKS
BAHAGIAN A: 80 MARKAH

INSTRUCTION:

This section consists of **FOUR (4)** subjective questions. Answer **ALL** questions.

ARAHAN:

Bahagian ini mengandungi EMPAT (4) soalan subjektif. Jawab semua soalan.

QUESTION 1

SOALAN 1

- CLO1
C1
- (a) Give **FOUR (4)** advantages of thermocouple.
Berikan EMPAT (4) kelebihan thermocouple.
- [4 marks]
[4 markah]
- CLO1
C2
- (b) Elaborate the principal operation of Resistance Temperature Detector (RTD).
Huraikan prinsip operasi sebuah perintang meter suhu (RTD).
- [6 marks]
[6 markah]
- CLO1
C3
- (c) In general, lights, fans and other home appliances are manually operated. Sometimes, due to the carelessness of human or unusual conditions, the process of controlling appliances may cause power wastage. However, we can use LDR (Light Depending Resistor) to control loads and to overcome the problem.
Write in detail the operation principle of LDR (Light Depending Resistor) with an aid of related circuit.
- Secara umum, lampu, kipas dan peralatan rumah lain dikendalikan secara manual. Kadangkala, disebabkan kecuaiian manusia atau keadaan luar jangkaan, proses kawalan perkakas boleh menyebabkan pembaziran kuasa. Namun, kita boleh menggunakan LDR (Light Depending Resistor) untuk mengawal beban dan mengatasi masalah tersebut.*

Tuliskan prinsip operasi LDR dengan dibantu litar yang bersesuaian.

[10 marks]

[10 markah]

QUESTION 2

SOALAN 2

CLO1
C1

- (a) State **FOUR (4)** applications of hydraulic system in industry.

*Nyatakan **EMPAT (4)** aplikasi sistem hidraulik di industri.*

[4 marks]

[4 markah]

CLO1
C2

- (b) “The external vane pump is a popular pumping principle and are often used as lubrication pumps in machine tools, in fluid power transfer units and as oil pumps in engines. This pump can be divided in single or double (two sets of vane) pump configurations.”

Based on the statement above, explain the operation of external vane pump.

“Pam Injap ialah prinsip pengepaman yang popular dan sering digunakan sebagai pam pelincir dalam alatan mesin, dalam unit pemindahan kuasa bendalir dan sebagai pam minyak dalam enjin. Pam ini boleh di bahagikan dalam konfigurasi tunggal atau dua (dua set gear).”

Berdasarkan pernyataan di atas, terangkan operasi pam injap luaran.

[6 marks]

[6 markah]

CLO1
C3

- (c) Write the working principle of the hydraulic circuit diagram as shown in Figure A2(c).

Tuliskan prinsip kerja litar hidraulik seperti yang ditunjukkan dalam Rajah A2(c).

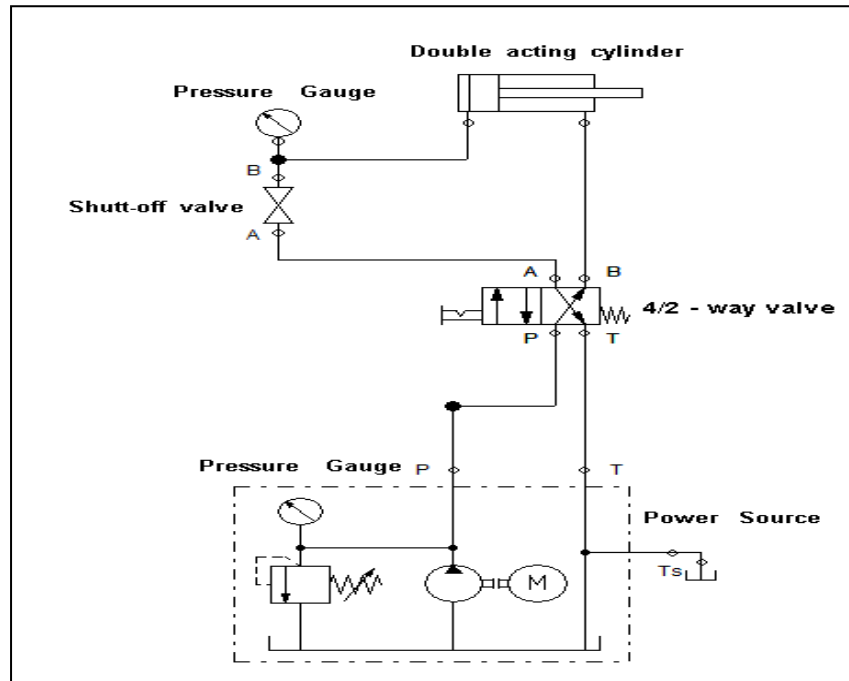

Figure A2(c)/ Figure A2(c)

[10 marks]

[10 markah]

QUESTION 3**SOALAN 3**

- (a) State **FOUR (4)** disadvantages of Hydraulic system.

CLO1
C1

*Nyatakan **EMPAT (4)** kekurangan sistem hidraulik.*

[4 marks]

[4 markah]

- (b) Elaborate the operations of direct acting and reverse acting for Diaphragm Actuator in figure A3b.

CLO1
C2

Perincikan operasi bagi direct acting dan reverse acting bagi Diaphragm Actuator di dalam Rajah A3b.

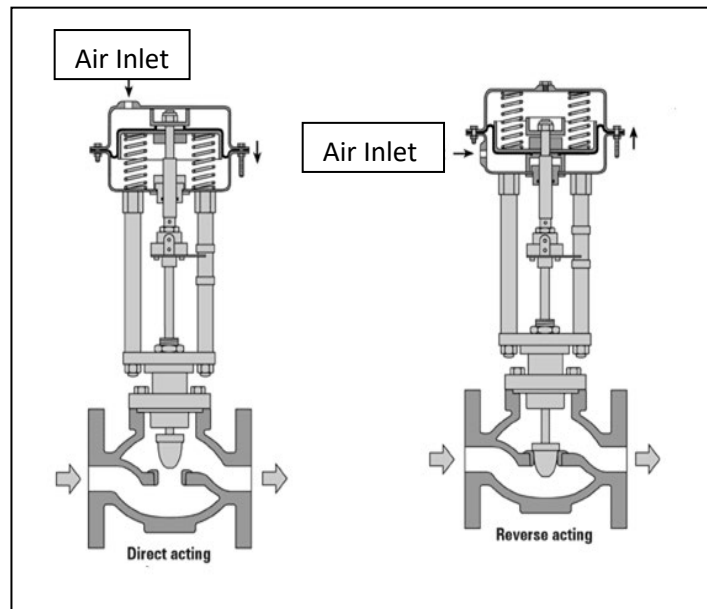

Figure A3b / Rajah A3b

[6 marks]

[6 markah]

CLO1
C3

- (c) A shut-off valve is a valve that safely manages the flow of hazardous fluids (liquids, gases, slurries, and fluidized solids). Shut-off valves are also known as on-off valves, cut-off valves, lockout valves, stop valves, etc. Figure A3c shows one of shut-off valve that controls the flow of a liquid or gas. Write the valve name, physical characteristic, valve operation, and the application of the valve.

Injap tutup ialah injap yang menguruskan pengaliran cecair berbahaya (cecair, gas, buburan dan pepejal terbendalir) dengan selamat. Injap tutup juga dikenali sebagai injap hidup, injap potong, injap kunci keluar, injap henti, dsb. Rajah A3c merupakan injap tertutup yang mengawal aliran cecair atau gas. Tuliskan nama, ciri fizikal, operasi, dan aplikasi injap.

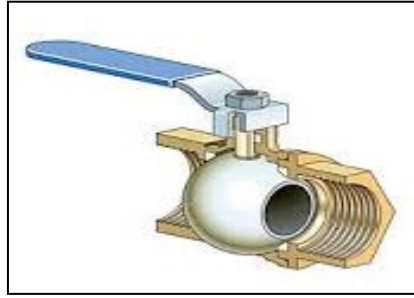

Figure A3c / Rajah A3c

[10 marks]

[10 markah]

QUESTION 4**SOALAN 4**CLO1
C1

- (a) List P&ID symbols for hydraulic line, data link, capillary tubing line, and centrifugal compressor.

Senaraikan simbol P&ID bagi garisan hidraulik, pautan data tiub kapilari, dan pemampat empar.

[4 marks]

[4 markah]

CLO1
C2

- (b) Explain the instrumentation and control symbols below.

Terangkan simbol instrumentasi dan kawalan di bawah.

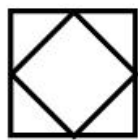

(a)



(b)

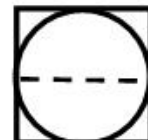

(c)

[6 marks]

[6 markah]

CLO1
C3

- (c) Figure A4c shows the equipment and line in the process industry which shows the piping of the process flow together with the installed equipment and instrumentation. Based on the figure, change the symbols label (i) to (viii) in P&IDs below to the equipment and line name.

Rajah A4c menunjukkan peralatan dan talian dalam industri proses yang menunjukkan perpaipan aliran proses bersama dengan peralatan dan instrumentasi yang dipasang. Berdasarkan rajah, tukarkan simbol kepada nama peralatan dan talian bagi yang berlabel (i) hingga (viii) dalam P&ID di bawah.

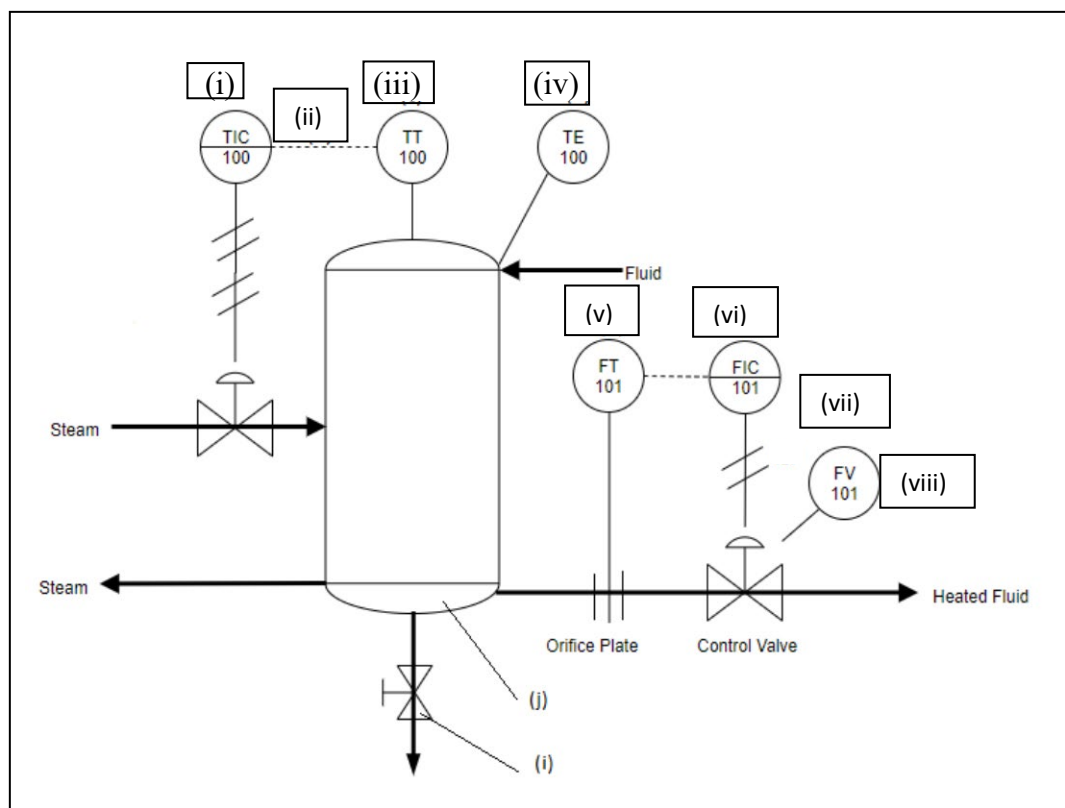

Figure A4c / Rajah A4c

[10 marks]

[10 markah]

SECTION B: 20 MARKS
BAHAGIAN B: 20 MARKAH

INSTRUCTION:

This section consists of **ONE (1)** essay question. Answer the questions.

ARAHAN:

*Bahagian ini mengandungi **SATU (1)** soalan esei. Jawab soalan tersebut.*

QUESTION 1

SOALAN 1

A pneumatic system can be used to operate the doors of public vehicles such as a bus. The opening and closing of the doors are controlled by two push-button PB1 and PB2. When PB1 is pressed, the doors will open and when PB2 is pressed, the doors will close. The cylinder is controlled by a 5/2 way double pilot pneumatic valve with 3/2 way single solenoid valve. Draw a complete electro-pneumatic control system circuit for the Bus Door System by using components mentioned.

Sistem pneumatik boleh digunakan untuk mengendalikan pintu kenderaan awam seperti bas. Pembukaan dan penutupan pintu dikawal oleh dua butang tekan PB1 dan PB2. Apabila PB1 ditekan, pintu akan terbuka dan apabila PB2 ditekan, pintu akan tertutup. Silinder dikawal oleh injap pneumatik pandu berganda 5/2 dengan injap solenoid tunggal 3/2. Lukiskan litar sistem kawalan elektro-pneumatik yang lengkap untuk Sistem Pintu Bas dengan menggunakan komponen yang dinyatakan.

[20 marks]

[20 markah]

SOALAN TAMAT

CLO1
C3
DP1, DP3,
DP4