

SULIT



**KEMENTERIAN PENDIDIKAN TINGGI
JABATAN PENDIDIKAN POLITEKNIK DAN KOLEJ KOMUNITI**

**BAHAGIAN PEPERIKSAAN DAN PENILAIAN
JABATAN PENDIDIKAN POLITEKNIK DAN KOLEJ KOMUNITI
KEMENTERIAN PENDIDIKAN TINGGI**

JABATAN KEJURUTERAAN MEKANIKAL

PEPERIKSAAN AKHIR

SESI II : 2022/2023

DJJ10033: WORKSHOP TECHNOLOGY

TARIKH : 15 JUN 2023

MASA : 8.30 PG – 10.30 PG (2 JAM)

Kertas ini mengandungi **SEPULUH (10)** halaman bercetak.

Struktur (4 soalan)

Dokumen sokongan yang disertakan : Tiada

JANGAN BUKA KERTAS SOALAN INI SEHINGGA DIARAHKAN

(CLO yang tertera hanya sebagai rujukan)

SULIT

INSTRUCTION:

This section consists of **FOUR (4)** structured questions. Answer **ALL** questions.

ARAHAN:

Bahagian ini mengandungi EMPAT (4) soalan berstruktur. Jawab SEMUA soalan.

QUESTION 1**SOALAN 1**

CLO1

- (a) Name the **SIX (6)** parts of the vernier caliper as shown in **Figure 1(a)**.
Namakan ENAM (6) bahagian angkup vernier seperti ditunjukkan dalam Rajah 1(a).

[6 marks]

[6 markah]

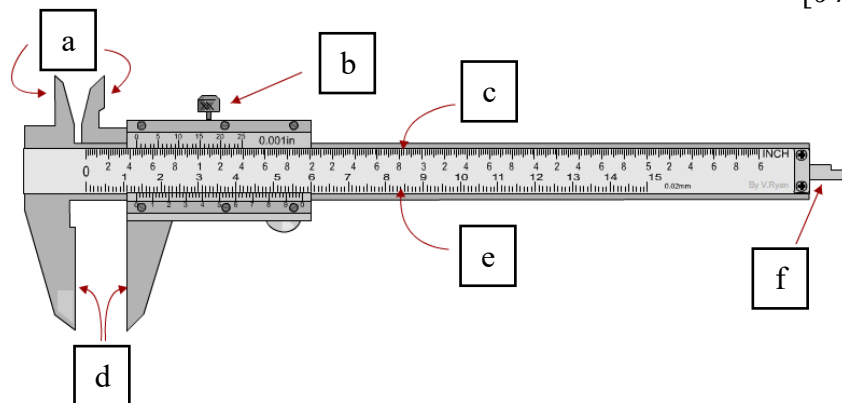

Figure 1(a)/Rajah 1(a)

CLO1

- (b) (i) Explain briefly **TWO (2)** types of hacksaw frame.
Terangkan secara ringkas DUA (2) jenis rangka gergaji besi.

[4 marks]

[4 markah]

[2 marks]

[2 markah]

(iii) Based on **Figure 1(b)**, match **THREE (3)** drilling process.

*Berpandukan **Rajah 1(b)**, padankan **TIGA (3)** proses penggerudian.*

[3 marks]

[3 markah]

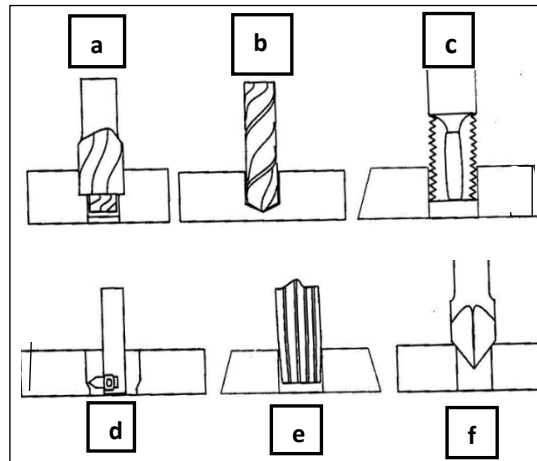

Boring
Center Drilling
Tapping
Counterboring
Reaming
Countersinking

Figure 1(b) / *Rajah 1(b)*

(iv) Explain briefly **FOUR (4)** holding drill bit methods.

*Terangkan secara ringkas **EMPAT (4)** kaedah memegang mata gerudi.*

[4 marks]

[4 markah]

CLO1

(c) Show in details the reading of micrometer in **Figure 1c (i)** and **(ii)** below.

*Tunjukkan secara terperinci bacaan bagi mikrometer dalam **Rajah 1c (i)** dan **(ii)** di bawah.*

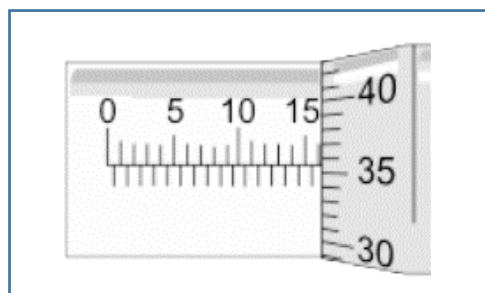

Figure 1c (i) / *Rajah 1c (i)*

[3 marks]

[3 markah]

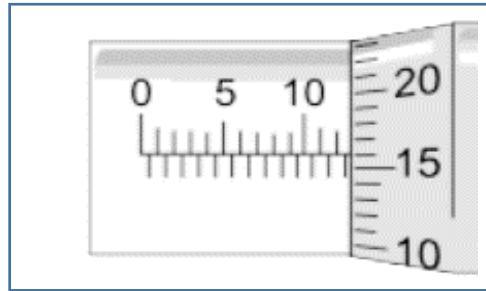

Figure 1c (ii) / Rajah 1c (ii)

[3 marks]

[3 markah]

QUESTION 2**SOALAN 2**

CLO1

- (a) (i) Describe the operation of lathe process in machining.

Terangkan operasi proses melarik dalam pemesinan.

[1 marks]

[1 markah]

- (ii) List
- TWO (2)**
- materials used in a tool bit.

*Senarai **DUA (2)** jenis bahan yang digunakan untuk mata alat.*

[2 marks]

[2 markah]

- (iii) Name
- TWO (2)**
- shapes and
- TWO (2)**
- functions of a tool bit.

*Namakan **DUA(2)** bentuk mata alat dan **DUA(2)** fungsinya.*

[4 marks]

[4 markah]

CLO1

- (b) (i) Explain about
- TWO (2)**
- types of angle on a tool bit and its function in lathe process.

*Terangkan mengenai **DUA (2)** jenis sudut pada mata alat dan fungsinya dalam proses melarik.*

[4 marks]

[4 markah]

- (ii) Discuss the process of boring and drilling in term of cutting operation.
Bincangkan tentang proses menggerudi dan menggerak dalam pengoperasi pemotongan.

[4 marks]

[4 markah]

CLO1

- (c) Based on **Table 2(c)** below, calculate the speed of spindle and feed rate to mill hole on alloy steel plate. Given size of hole is 15 mm, five teeth on milling cutter and CPT = 0.25.

*Berdasarkan **Jadual 2(c)** di bawah, kirakan kelajuan spindal dan kadar suapan untuk mengisar lubang pada plat aluminium. Diberi saiz lubang adalah 15 mm, lima gigi pada mata pemotong dan CPT=0.25.*

Material	Cutting Speed (m/min)
Alloy Steel	20
Tool Steel	18
Cast Iron	25
Machine Steel	30
Aluminium	300

Table 2(c) / *Jadual 2(c)*

[10 marks]

[10 markah]

QUESTION 3**SOALAN 3**

CLO2

- (a) In car manufacturing industry, gear is an important component to transfer power from engine to other parts of a car. List **FIVE (5)** types of gears.

*Di dalam industri pembuatan kereta, gear merupakan satu komponen penting untuk menghantar kuasa dari enjin ke bahagian lain kereta. Senaraikan **LIMA (5)** jenis gear.*

[5 marks]

[5 markah]

CLO2

- (b) Spur gear and helix gear are two major gears in transmission unit. Based on the statement, explain about:

Gear taji dan gear helik merupakan dua gear utama di dalam unit penghantaran. Berdasarkan kenyataan tersebut, terangkan tentang:

- (i) **ONE (1)** major difference between two types of gears.

***SATU (1)** perbezaan utama di antara dua jenis gear tersebut.*

[3 marks]

[3 markah]

- (ii) **THREE (3)** characteristic of spur gear.

***TIGA (3)** ciri gear taji.*

[3 marks]

[3 markah]

- (iii) Level of strength and noise between helix gear compared with a spur gear.

Tahap kekuatan dan kebisingan antara gear heliks berbanding gear taji.

[2 marks]

[2 markah]

CLO2

- (c) Based on **Figure 3(c)**, write a CNC coordinate for P1, P2, P3 and P4 using the following system:

*Berdasarkan **Rajah 3(c)**, tulis koordinat program CNC bagi P1, P2, P3 dan P4 menggunakan sistem berikut:*

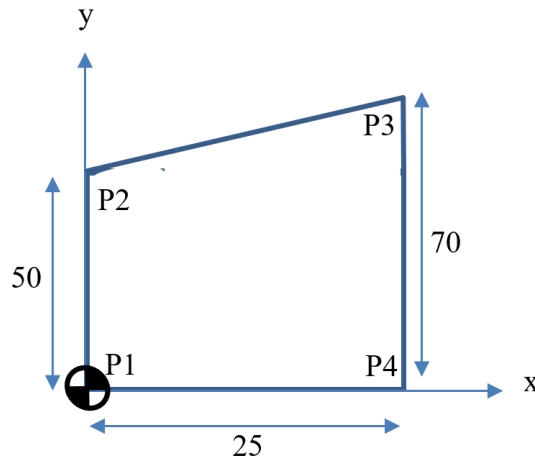

Figure 3(c) / *Rajah 3(c)*

- (i) Absolute Coordinate System.

Sistem Koordinat Mutlak.

[5 marks]

[5 markah]

- (ii) Incremental Coordinate System.

Sistem Koordinat Tokokan.

[5 marks]

[5 markah]

- (iii) Write down the difference between Absolute Coordinate System and Incremental Coordinate System.

Tuliskan perbezaan di antara Sistem Koordinat Mutlak dan Sistem Koordinat Tokokan.

[2 marks]

[2 markah]

QUESTION 4**SOALAN 4**

CLO2

- (a) (i) Oxy-acetylene welding are commonly used in heavy industry nowadays. Define the meaning of oxy-acetylene in welding process.

Kimpalan oksigen-asetilena banyak digunakan dalam industri berat masa kini. Terangkan maksud oksigen-asetilena dalam proses kimpalan.

[2 marks]

[2 markah]

- (ii) List **FOUR (4)** components of oxy-acetylene machine.

Senaraikan EMPAT (4) komponen mesin oksigen-asetilena.

[4 marks]

[4 markah]

CLO2

- (b) (i) Heat zone defect in SMAW process is the major issue in welding. Based on the statement, discuss the heat zone effect on mechanical properties and how to control the effect on base metal.

Kecacatan zon panas di dalam proses SMAW merupakan isu utama di dalam kimpalan. Berdasarkan kenyataan tersebut, bincangkan kesan zon panas ke atas sifat mekanikal dan bagaimana untuk mengawal kesannya pada logam asas.

[3 marks]

[3 markah]

- (ii) Explain the key point of difference between GMAW and GTAW in term of electrode and filler metal.

Terangkan kunci utama perbezaan di antara GMAW dan GTAW dari segi elektrod dan bahan penambah.

[3 marks]

[3 markah]

- (iii) Based on **Table 4b(iii)**, match the travel speed of beat on **Figure 4b(iii)** below.

*Berdasarkan **Jadual 4b(iii)**, padankan laju perjalanan kumai pada **Rajah 4b (iii)** di bawah.*

[3 marks]

[3 markah]

Normal weld	Speed to fast
Current to low	Speed to slow
Current to high	Arc to long

Table 4b(iii) / *Jadual 4b(iii)*

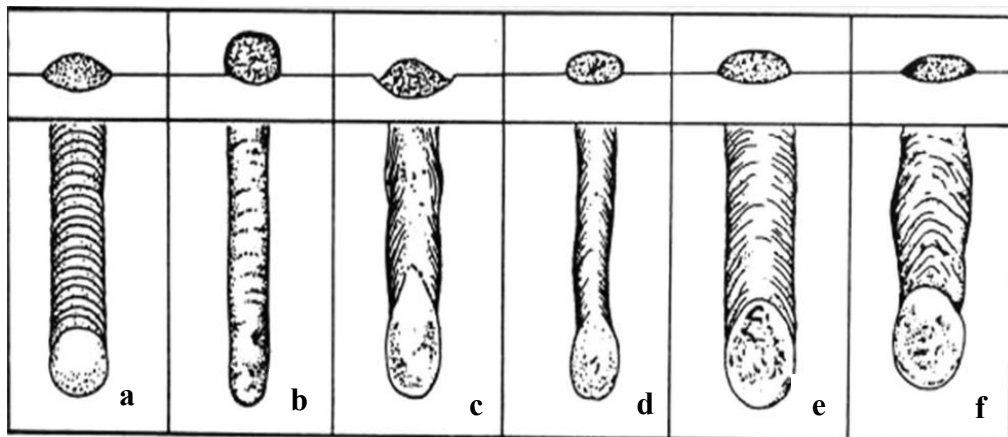

Figure 4b(iii) / *Rajah 4b(iii)*

CLO2

- (c) (i) Polarity is an important element in Shielded Metal Arc Welding (SMAW). In SMAW process, size and penetration of bead can be control by polarity chosen by welder. Based on this statement, sketch **TWO (2)** types of polarity in SMAW process.

*Polariti adalah satu element penting di dalam Kimpalan Arka Logam Terlindung (SMAW). Di dalam SMAW, saiz dan penembusan kumai boleh dikawal oleh polarity yang dipilih oleh pengimpal. Berdasarkan kenyataan ini, lakarkan **DUA (2)** jenis polarity dalam proses SMAW.*

[5 marks]

[5 markah]

- (ii) There are three basic types of oxy-acetylene flames in gas welding. Write down **THREE (3)** types of flames and sketch **TWO (2)** of the flames.

*Terdapat tiga jenis asas api oksi-astelina dalam kimpalan gas. Tuliskan **TIGA (3)** jenis api dan lakarkan **DUA (2)** api tersebut.*

[5 marks]

[5 markah]

SOALAN TAMAT